

PNEUMATIC CYLINDER 3/8" PORTS  
100MM BORE X 50MM STROKE  
PLUMBED BY OTHERS, AIR SUPPLY  
MUST BE CLEAN, DRY, COMPRESSED  
AIR REGULATED TO 85 PSI. MIN.

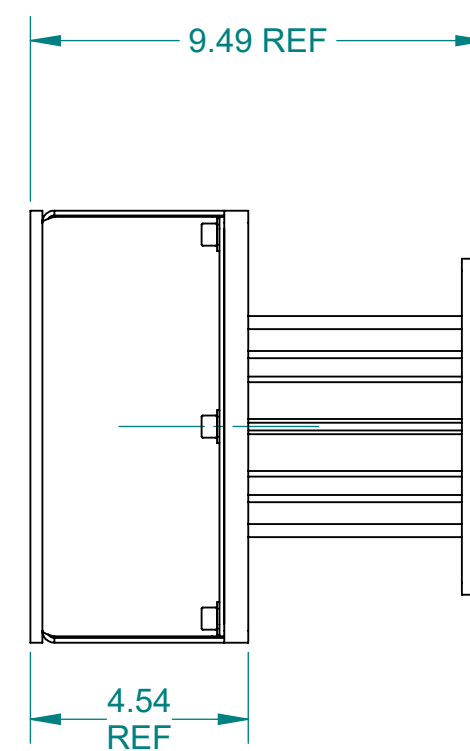

DETAIL OF ASSEMBLY  
SCALE:1:4

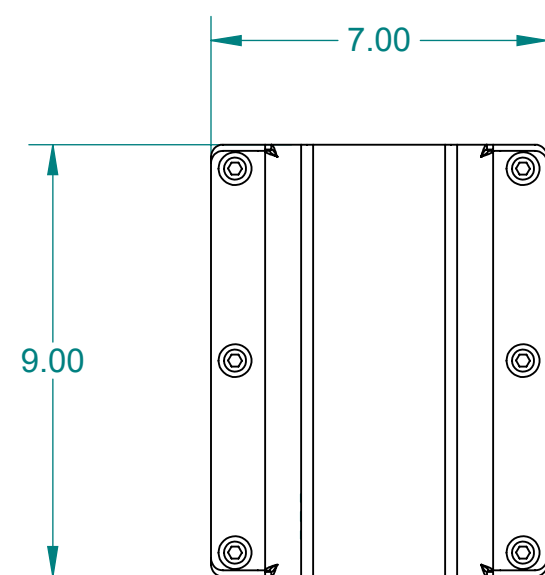
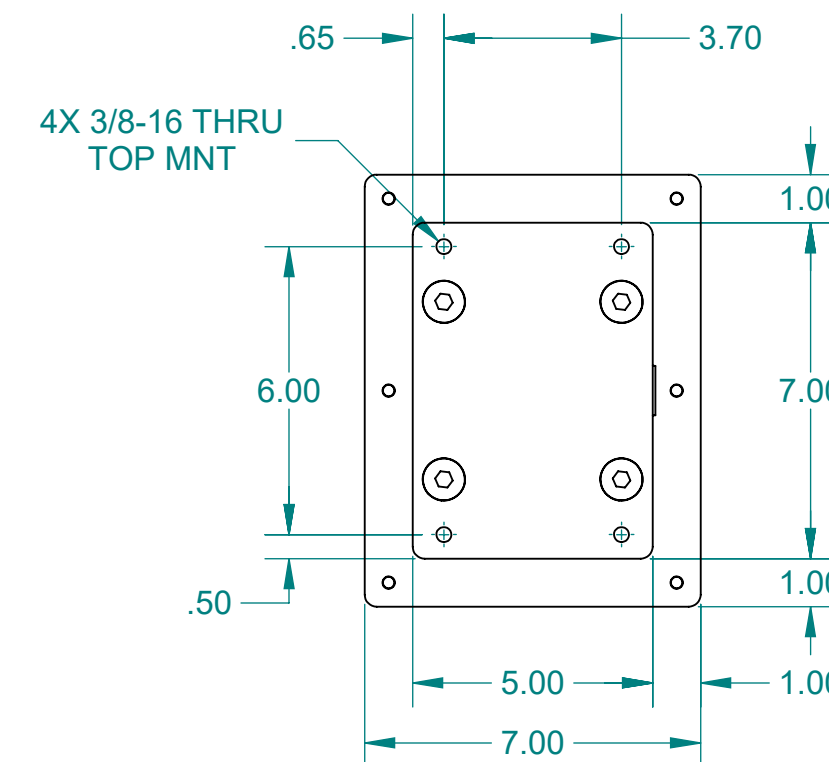

180° MAX OPERATING TEMP  
CUSTOMARY GRADE

APPROXIMATE WEIGHT: 34 LBS

ALL DIMENSIONS ARE IN INCHES EXCEPT AS NOTED. C SIZE - SHEET 1 OF 1

This drawing and all of the elements thereof, including the design and principles of construction disclosed, is the sole and exclusive property of Industrial Magnetics, Inc. and is being submitted by Industrial Magnetics, Inc. for the limited purpose of assisting the designated recipient to evaluate the services of Industrial Magnetics, Inc. This drawing may not be used for any other purpose, nor may it be copied, reproduced, loaned, transferred, or communicated to any other person, either verbally or in writing, without the written consent of Industrial Magnetics, Inc.

**INDUSTRIAL MAGNETICS, INC.**  
01385 M-75 SOUTH  
BOYNE CITY, MI 49712-9689  
WWW.MAGNETICS.COM • (231) 582-3100

**WALKER MAGNETICS**

TOLERANCES EXCEPT AS NOTED DECIMAL .00"=±.030" ANGULAR ±1° .000"=±.015"	RELEASED DATE 6/5/2020 DRAWN BY D.JOHNSON RELEASED BY G.SMITH	R & D SCALE SHOWN DATE 3-8-12	DESCRIPTION PNEUMATIC SHEET FANNER X 9.00 LG RARE EARTH WITH 100MM CYL	PART NO. ARF09	DRAWING NO. 55485
--	--	---	--	-------------------	----------------------