

WEAR STRIPS ON THE MAGNETIC FACE OF FANNER.

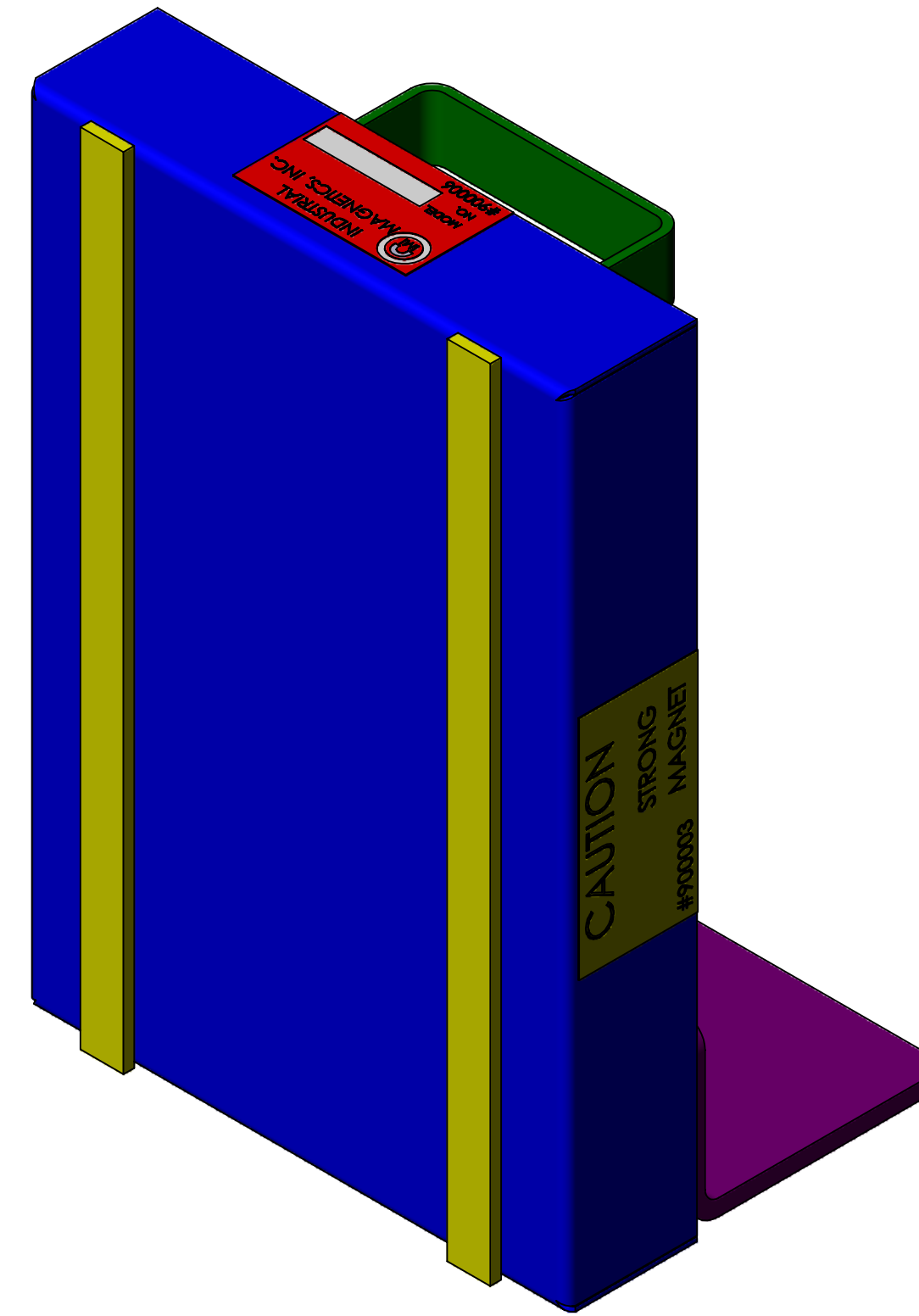

APPROXIMATE WEIGHT: 21 LBS

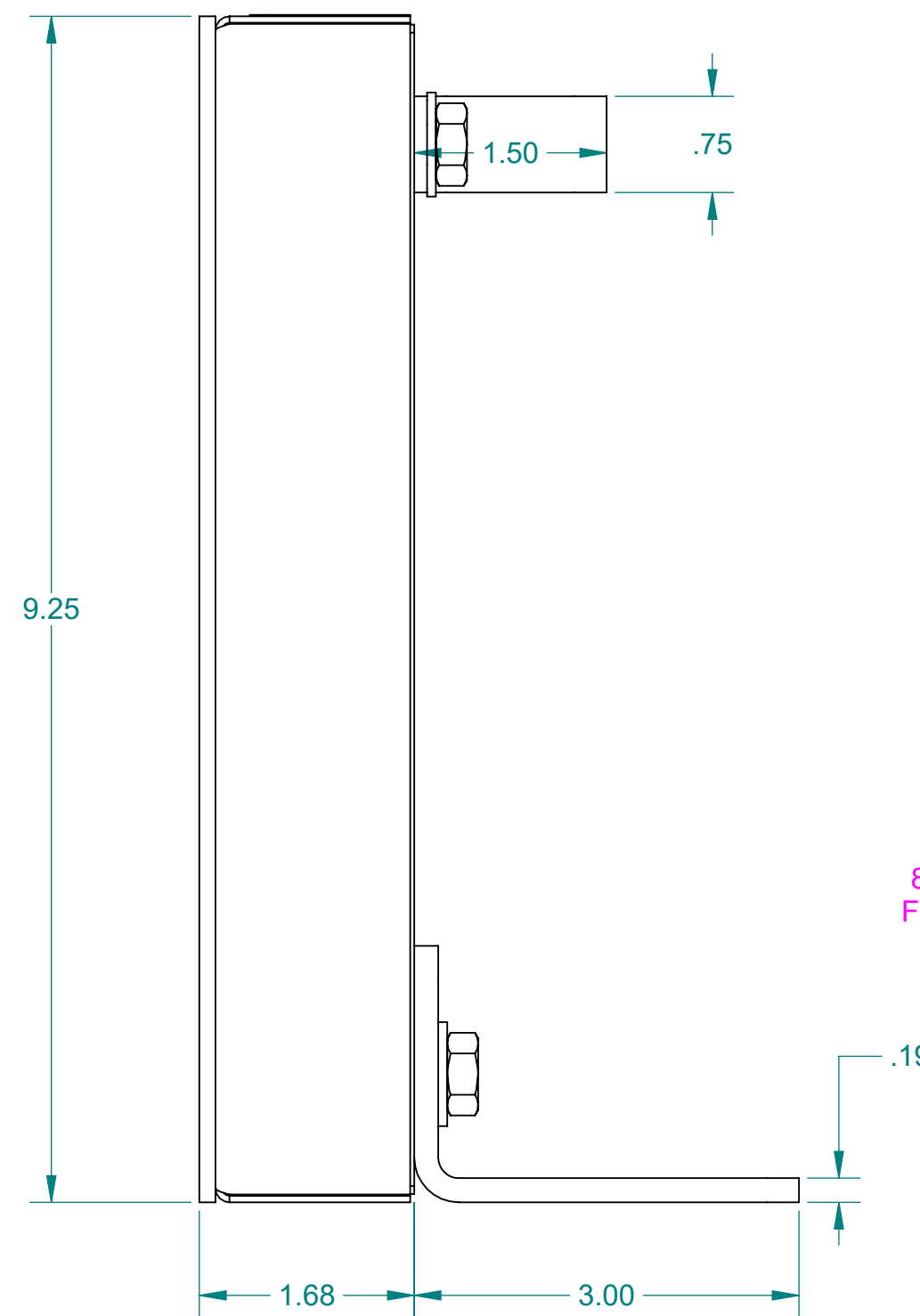
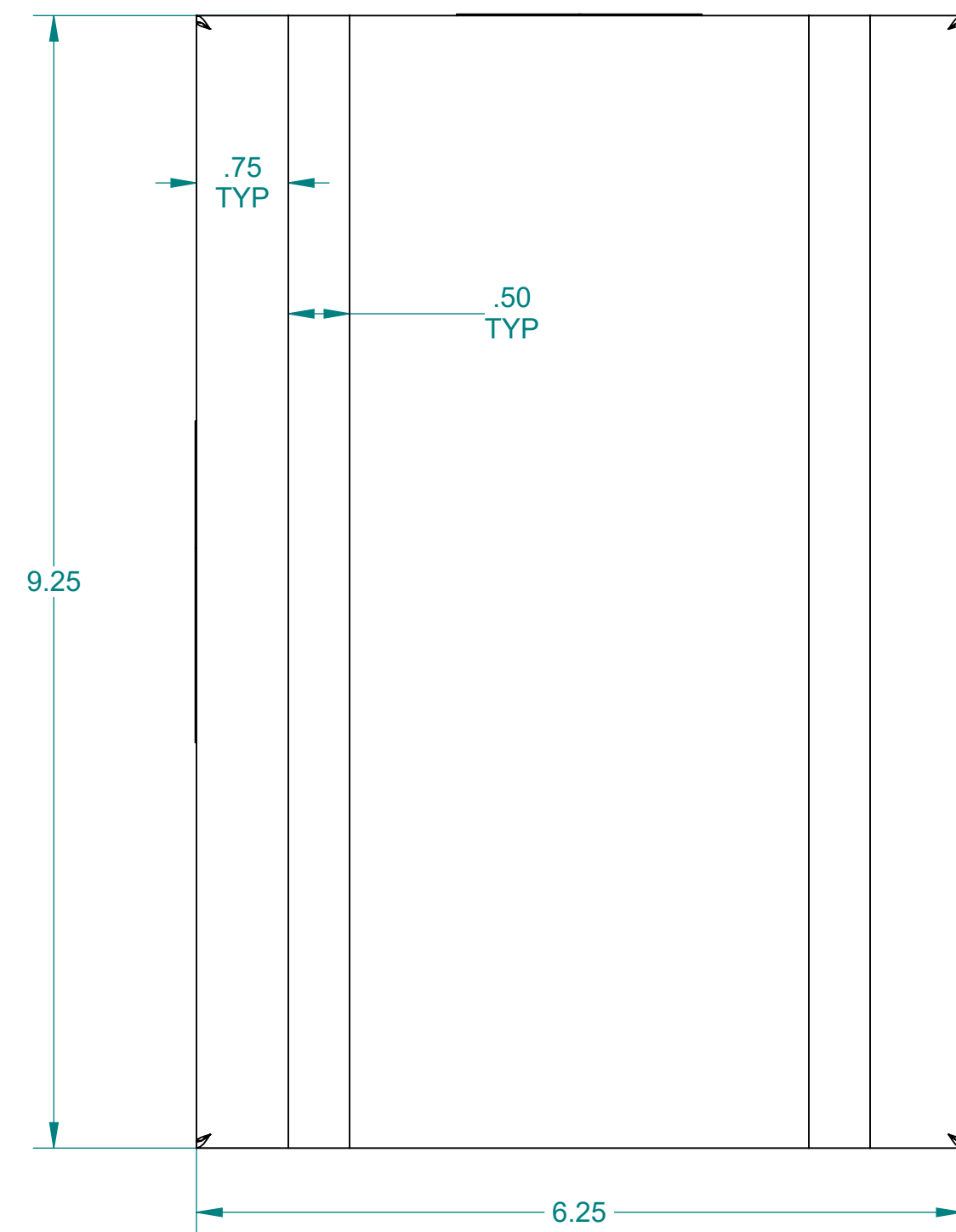

8X 3/8-16 THRU BP FOR MOUNTING KIT

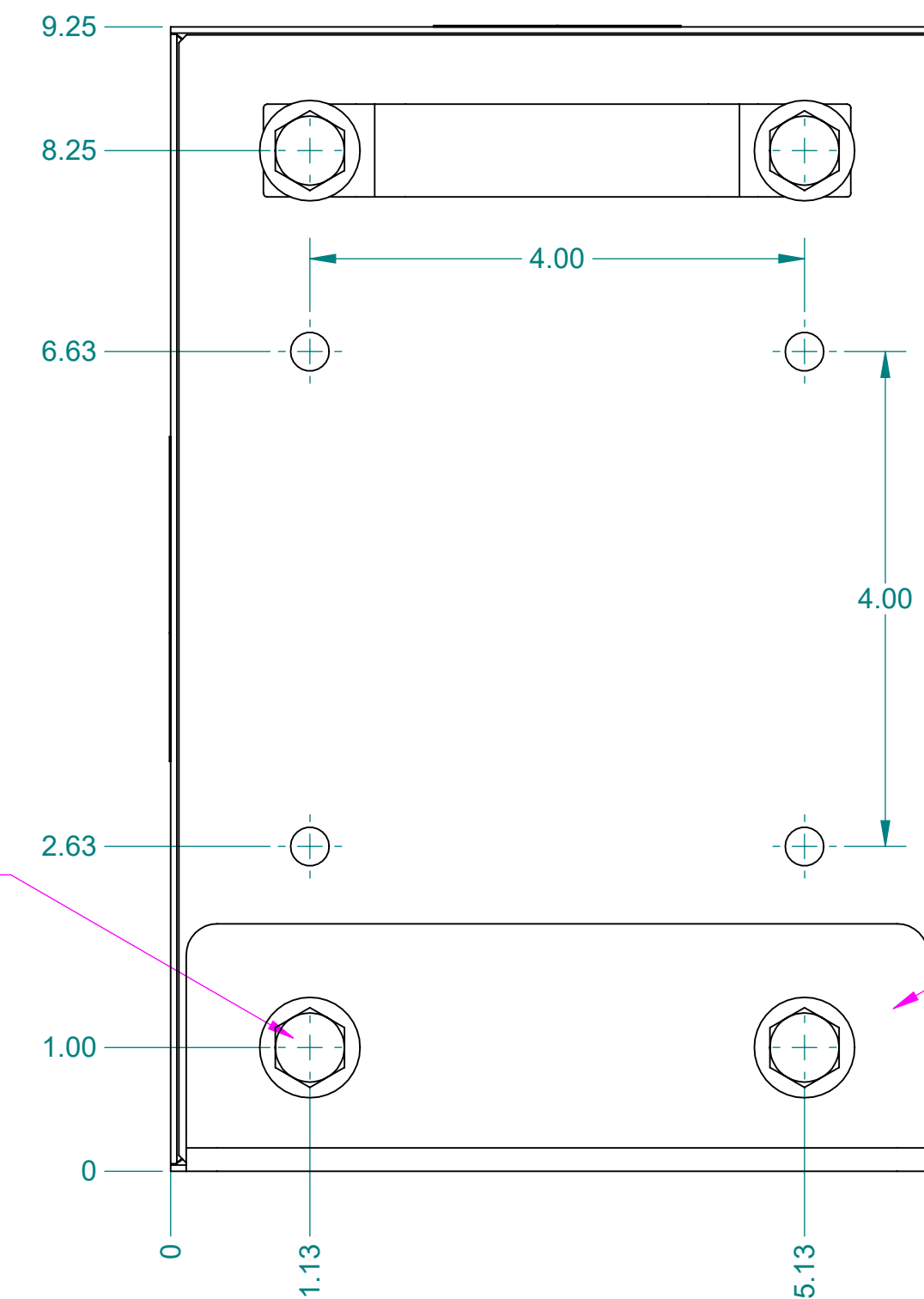

CUSTOMER NOTE:
FANNER SHOWN WITH HANDLE/ANGLE KIT ATTACHED FOR REF. ONLY.
(IMI SHIPS HANDLE/ANGLE KIT LOOSE FOR CUSTOMER TO ATTACH IF NECESSARY)

DETAIL OF ASSEMBLY
SCALE:3:4

CUSTOMARY GRADE

ALL DIMENSIONS ARE IN INCHES EXCEPT AS NOTED.

SHEET 1 OF 1

This drawing and all of the elements thereof, including the design and principles of construction disclosed, is the sole and exclusive property of Industrial Magnetics, Inc. and is being submitted by Industrial Magnetics, Inc. for the limited purpose of assisting the designated recipient to evaluate the services of Industrial Magnetics, Inc. This drawing may not be used for any other purpose, nor may it be copied, reproduced, loaned, transferred, or communicated to any other person, either verbally or in writing, without the written consent of Industrial Magnetics, Inc.

INDUSTRIAL MAGNETICS, INC.
01385 M-75 SOUTH BOYNE CITY, MICHIGAN 49712-9689 (231) 582-3100

TOLERANCES EXCEPT AS NOTED		RELEASED DATE	R & D	DESCRIPTION
DECIMAL	ANGULAR	DRAWN BY	SCALE	9" THIN GAUGE SHEET FANNER
.00" = ±.030"	±1°	S. ALLAN	FULL	
.000" = ±.015"		RELEASED BY	DATE	PART NO.
			2-12-01	TNF09
				DRAWING NO. 21985