

APPROXIMATE WEIGHT: 27 LBS

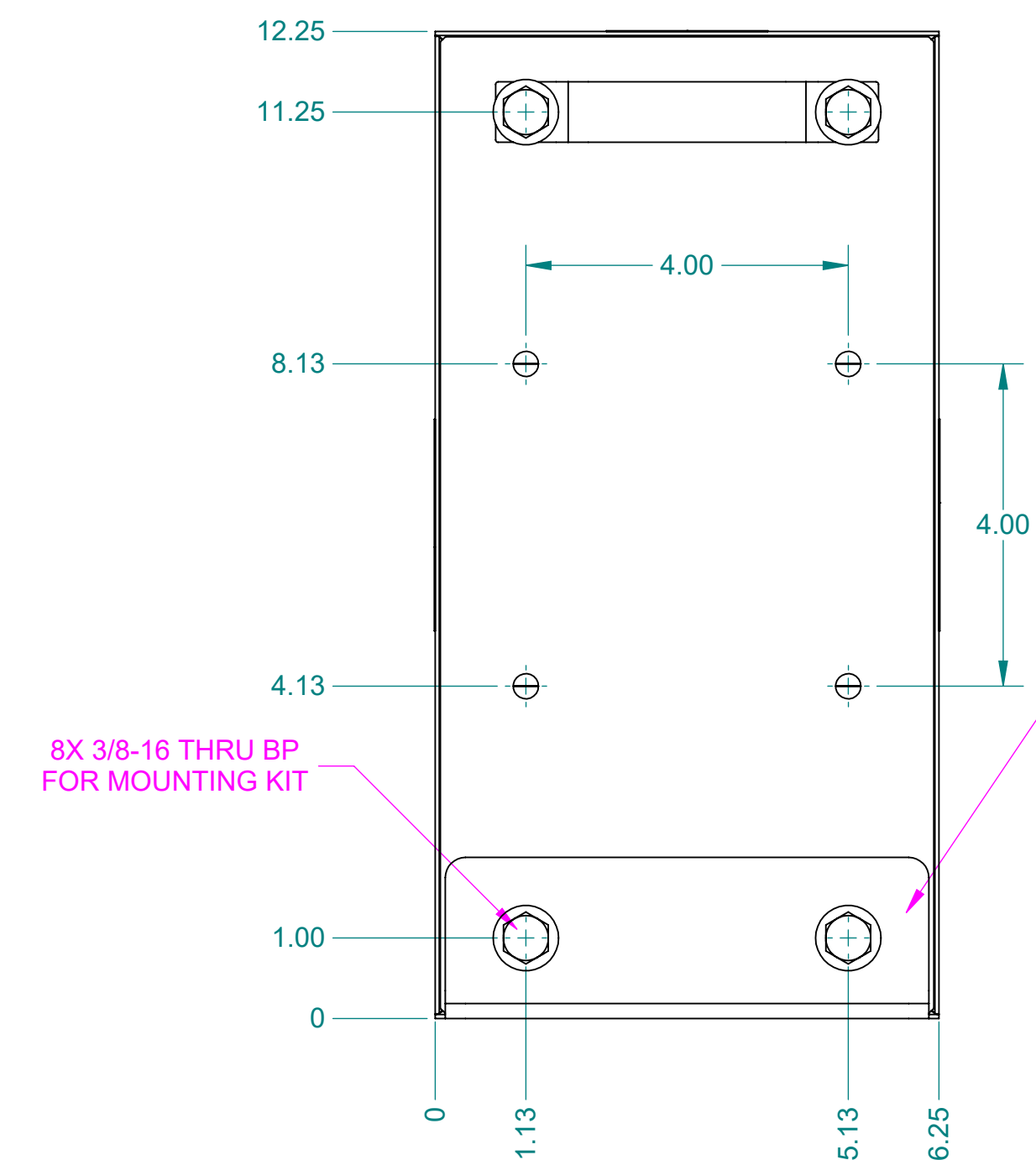
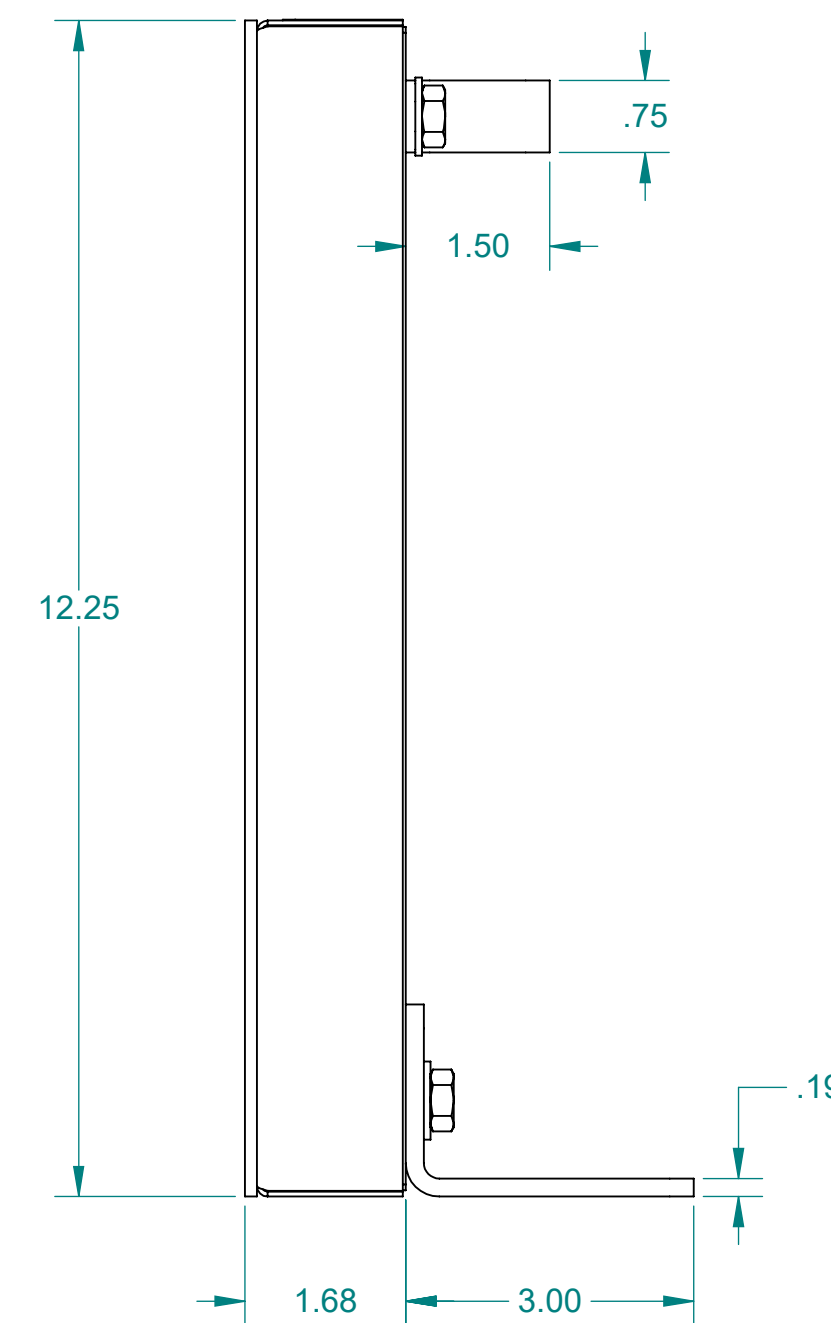
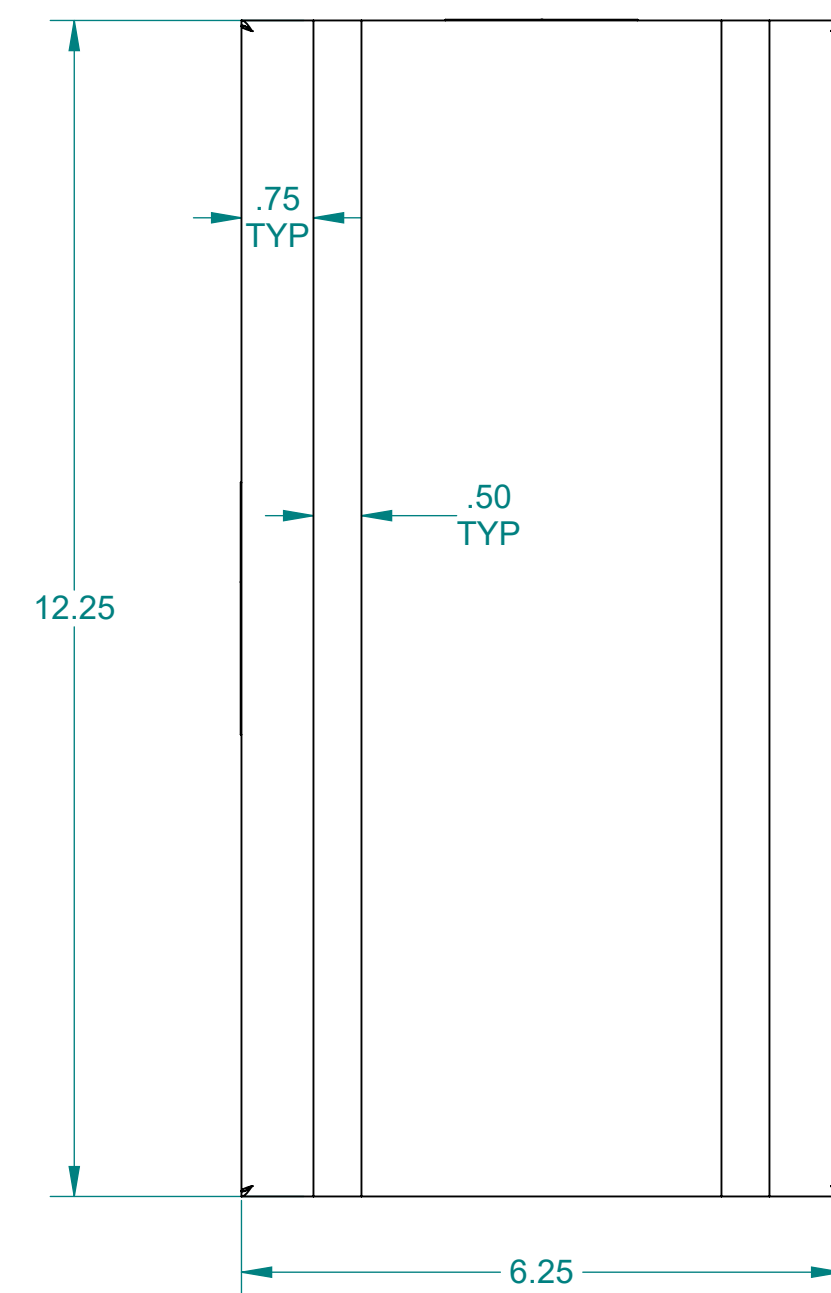

CUSTOMER NOTE:
FANNER SHOWN WITH HANDLE/ANGLE KIT
ATTACHED FOR REF. ONLY.
(IMI SHIPS HANDLE/ANGLE KIT LOOSE
FOR CUSTOMER TO ATTACH IF NECESSARY)

DETAIL OF ASSEMBLY
SCALE:1:2

CUSTOMARY GRADE

ALL DIMENSIONS ARE IN INCHES EXCEPT AS NOTED.				SHEET 1 OF 1	
<small>This drawing and all of the elements thereof, including the design and principles of construction disclosed, is the sole and exclusive property of Industrial Magnetics, Inc. and is being submitted by Industrial Magnetics, Inc. for the limited purpose of assisting the designated recipient to evaluate the services of Industrial Magnetics, Inc. This drawing may not be used for any other purpose, nor may it be copied, reproduced, loaned, transferred, or communicated to any other person, either verbally or in writing, without the written consent of Industrial Magnetics, Inc.</small>					
TOLERANCES EXCEPT AS NOTED DECIMAL .00"=±.030" ANGULAR ±1° .000"=±.015"		RELEASED DATE 8/24/2018	R & D SCALE FULL	DESCRIPTION 12" THIN GAUGE SHEET FANNER	
DRAWN BY S. ALLAN		RELEASED BY E. PASCOE	DATE 2-12-01	PART NO. TNF12	DRAWING NO. 21986

