

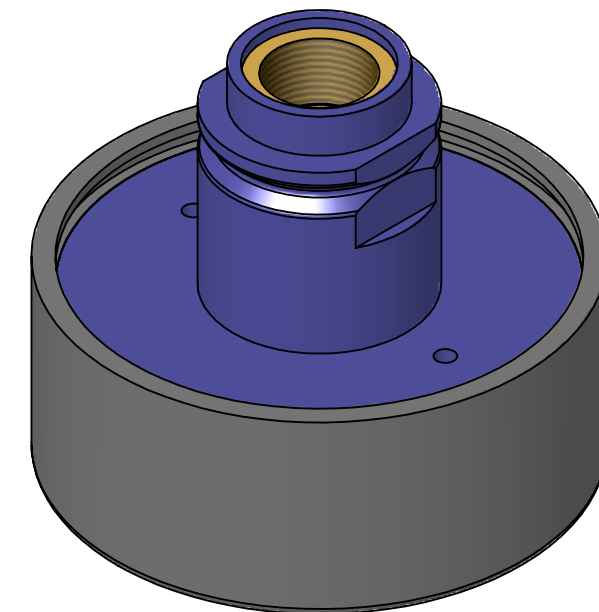

DETAIL OF TPLP30
SCALE:1:1



APPROXIMATE WEIGHT: 0.8 LBS

ALL DIMENSIONS ARE IN INCHES EXCEPT AS NOTED.			B SIZE - SHEET 1 OF 1	
<p>This drawing and all of the elements thereof, including the design and principles of construction disclosed, is the sole and exclusive property of Industrial Magnetics, Inc. and is being submitted by Industrial Magnetics, Inc. for the limited purpose of assisting the designated recipient to evaluate the services of Industrial Magnetics, Inc. This drawing may not be used for any other purpose, nor may it be copied, reproduced, loaned, transferred, or communicated to any other person, either verbally or in writing, without the written consent of Industrial Magnetics, Inc.</p>			 INDUSTRIAL MAGNETICS, INC. 01385 M-75 SOUTH BOYNE CITY, MI 49712-9689 WWW.MAGNETICS.COM • (231) 582-3100	
TOLERANCES EXCEPT AS NOTED DECIMAL ANGULAR .00"=±.030" ±1° .000"=±.015"	RELEASED DATE 11/9/2018 DRAWN BY J. MOSLEY RELEASED BY E.PASCOE	R & D SCALE SHOWN DATE 4-7-05	DESCRIPTION TRANSPORTER LOW PROFILE 3.00 DIA	
			PART NO. TPLP30	DRAWING NO. 50372