

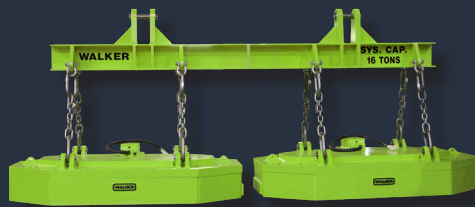

INDUSTRIAL
MAGNETICS®

LIFTING

MAGNETS



magnetics.com

LIFTING SOLUTIONS CATALOG - 202D

OUR BRAND VALUES

LOYALTY, DEPENDABILITY AND TRUST

Our culture of loyalty promotes lasting careers at Industrial Magnetics, which helps staff form longstanding relationships with customers who know us by name. Customers can depend on us to provide timely service, around-the-clock technical support and durable products that last. Thanks to our knowledgeable experts with decades of industry experience, customers trust the quality and accuracy of our recommended solutions.

Industrial Magnetics, Inc. is an industry leader in providing both permanent magnets and electromagnets for work holding, lifting, fixturing, conveying and magnetic separation. At IMI, our specialty is custom fabricating! We design, engineer and manufacture magnetic assemblies and magnetic separation devices for our customers' specific requirements, and take pride in the quality and performance of our products. With worldwide distribution through a combination of a direct sales force and manufacturers representatives, we strive to provide personalized service and innovative solutions to meet the exact needs of your application. **THREE PRODUCT GROUPS, ONE GOAL...the right product for the application at the right time for our customer**



IMI is proud to be a United States - based manufacturer of magnetic assemblies and our USA M.A.D.E.™ logo is how we like to show it. You will find our USA M.A.D.E.™ logo on any of our products that are **Manufactured • Assembled • Designed • Engineered** here, in the USA, at our facilities.

TABLE OF CONTENTS

» Magnet Basics & Safety	2-3
» Cutting Table Devices	4-5
» Permanent Ceramic Magnetic Lifts.....	6
» Permanent Rare Earth Magnetic Lifts	7-9
» FX Series Lifting Magnets	10-15
» Walker Lifting Magnets.....	16-17
» Permanent Magnetic Sheet & Small Plate Lift Systems	18-19
» Cutting Tables Loading/Unloading Systems.....	20
» Heavy Plate Handling & Lifting.....	21
» Lifts for Heavy Tubes, Structural Profiles & Bundles	22-23
» Lifts for Hot Plates & Billets	24
» Heavy Lifting	25
» Lifts for Coils & Large Billets	26
» Walker Scrap Lifting Magnets	27-28
» Lift Magnet Systems Controls	29
» Transporters & End of Arm Tooling.....	30-31
» Lifting Accessories.....	32
» Permanent Magnetic Tube Lifters & Palletizers/Depalletizers	33
» Custom Magnet Lifting Specialists.....	34-35
» Manhole Cover Lifts	36
» Manhole Cover Lift Products.....	37
» Other Magnetic Solutions.....	38
» Walker Magnet Service & Repair.....	39

MAGNET BASICS & SAFETY INFORMATION

LOSS OF MAGNETISM

Under normal use conditions, a permanent magnet can experience a decrease in its original holding value. The most common factors which can cause a loss of strength include:

- » Every day wear and tear on the magnet face.
- » Exposure to extreme temperatures outside the magnet's temperature range.
- » Severe blow or shock to the magnet. Do not use a blunt instrument to position the magnet on the load.
- » Exposure to electrical currents. Never place the magnet next to a large motor or generator. Never use the magnet as part of a welding ground circuit.
- » Exposure to vibration.

MAGNET SAFETY FACTORS

Our magnetic material meets Magnetic Materials Producers Association (MMPA) standards for physical quality and magnetic properties. Some magnetic material is brittle in nature and minor defects such as chips and hairline cracks are unavoidable. When selecting a magnet for your application, consider the following factors that may affect performance of the magnet:

- » Physical shape of the part where contacting the magnet will affect the holding power of the magnet
- » The surface area & the condition of your steel item (rough, rusty, dirty, oily, painted or coated surfaces) will create a gap and have negative affect on the magnets hold to the surface (also known as Air-gap*)
- » Part size, thickness weight and orientation must be considered to help determine the strength of magnet required
- » The ambient or part temperature for the application will help determine the type of magnet material needed
- » Gauss levels limits for handling a part may prevent the use of magnets or limit the type/strength that can be used
- » If protecting the finish of a part is required the type of magnet used may be limited in order to contact the part without damaging the finish

*Air gap - The air, protective coating, paint, galvanizing, oil, rust, dirt, etc. between the magnet and the part.

LIFT MAGNET SAFETY FACTORS

Lift magnets can be effective even when the surfaces of the magnet and/or load have dirt, paint, scale or other debris on them. However, the best efficiency of any magnetic lift is achieved when both the magnet and the load are clean with good, uninterrupted contact between them (minimal air gap).

- » Avoid positioning the magnet in places on the load that have limited contact, are dirty or have rough surface texture
- » Clear any foreign material from the load before setting the magnet on it
- » Often check the mechanical condition of the magnetic contact face to make sure it has not been damaged during use
- » After using the lift magnet, protect the pole surfaces with oil to prevent them from rusting

Lifting ferrous items using a magnet requires a good look at the length, width and thickness of the item. Thin metals do not absorb as many of the magnetic flux lines (magnetic energy) as thicker metals. Thin metals also flex, causing the steel to peel- off the magnet. Equally important is the physical size, flatness, surface conditions and type of steel. The charts below illustrate how surface finish and Carbon content affect lifting value.

PERCENTAGE OF STATED LIFTING POWER BY MATERIAL

CARBON CONTENT	LOW CARBON 0.05 - 0.29%	100%
	MODERATE CARBON 0.30 - 0.59%	85%
	HIGH CARBON 0.60 - 0.99%	75%
	HIGHER CARBON = HIGHER RESIDUAL*	

PERCENTAGE OF STATED LIFTING POWER BY SURFACE FINISH

SURFACE FINISH	GROUND SURFACE	100%
	ROUGH MACHINED	100%
	FOUNDRY FINISH	85%
	ROUGH CAST	65%

*HIGH CARBON STEEL (TOOL STEEL) WILL ABSORB MAGNETISM & MAY MAGNETICALLY STICK TO STEEL SURFACES, SUCH AS THE MAGNET, OR ATTRACT FERROUS PARTICLES.

DESIGN FACTOR

Design Factor is the relation of the magnet's labeled Working Load Limit (WLL) compared to the magnet's maximum lifting value under ideal conditions. Ideal conditions are when a magnet is new and pulled off a newly machined, thick, low carbon steel plate. **The pounds of pull it takes to break the magnet away from the steel surface is the "maximum" lifting value.**

Working Load Limit (de-rating) values are then determined by taking this maximum lifting value and dividing it by the manufacturer's design factor.

 **Unless otherwise noted, magnet working load limits are stated up to 50% of the actual value. These magnets may reach substantially higher holding values, but the surface condition of the part may affect the magnet's performance capabilities.**

Design factors are minimum 2:1 and most cases 3:1. This means a magnet with a 3:1 design factor and labeled with a working load limit of 1,000 lbs will have a break-a-way force minimum of 3,000 lbs. The labeled WLL is stated for the benefit and safety of the user, due to the fact that ideal conditions rarely exist in the field. The steel that you are lifting may have scale, rust, dirt, or coatings on its surface; or the surface of the magnet itself may be worn. Any of these conditions will cause lower lifting values. Pick a lift magnet that has a WLL value slightly higher than the weight of your part.

ASME B30.20 LIFTING STANDARDS & ASME BTH-1 DESIGN STANDARD

The American Society of Mechanical Engineers (ASME) has established standards for Below-the-Hook Lifting Devices. These standards apply to the marking, construction, installation, inspection, testing, maintenance, and operation of all lifting magnets when used for single or multiple steel piece handling operations in which the operator of the lifting magnet is required to manually position the lifting magnet on the load and manually guide the load during its movement, or in close proximity to people.

Lifting devices designed to these Standards shall comply with ASME B30.20, Below-the-Hook Lifting Devices. Designed and manufactured to ASME BTH-1 Standard.

Industrial Magnetics, Inc. offers several lift magnet options that conform to the ASME B30.20 Standards

CUTTING TABLE TOOLS & RETRIEVERS

MAGNETIC SHEET HANDLERS



FEATURES:

- » Lift or move sheets, plates, hot or oily parts
- » Handle sheets stacked horizontally or vertically
- » Protect workers from cuts, slivers, nicks & burns
- » Increase productivity

Note: Not intended to be used with a crane

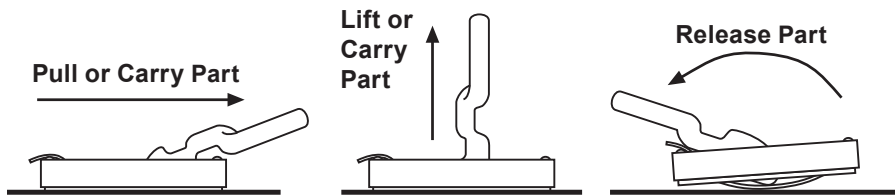

Lift - lbs (kg)	Th. (in)	Wd. (in)	Handle Ln. (in)	Overall. Ln. (in)	Mag. Ln. (in)	Mag. Th. (in)	Wt. (lbs)	Max. Penetration (in)	No. of Poles	Model No.
50.0 (22.6)	4	3-5/8	8	11-1/2	6-1/8	1-3/8	3.75	3/16	4	B100
125.0 (56.7)	4	3-5/8	8	11-1/2	6-1/8	1-3/8	3.75	5/16	4	B250
200.0 (90.7)	4	7-1/4	8	11-1/2	6-1/8	1-3/8	7.25	5/16	8	B400
300.0 (136.0)	4	7-1/4	8	11-1/2	6-1/8	1-3/8	8.25	5/16	10	B600

LOAD CONTROL MAGNET

Stay safe. This extremely powerful On/Off Permanent Rare Earth magnet lets you guide loads into position without being in close proximity. Attach the On/Off permanent magnet to a corner or along the side of your load. As the load is lifted, the Load Control Magnet's articulating connection to the lightweight telescoping pole allows you to control and position the load exactly where you want without endangering yourself, others or expensive equipment, should your lifting device fail.

FEATURES:

- » Powerful On/Off Rare Earth Magnet
- » Works on Flat and Pipe
- » Pole telescopes from 6' to 12'
- » Buy the magnet separately, use your own pole

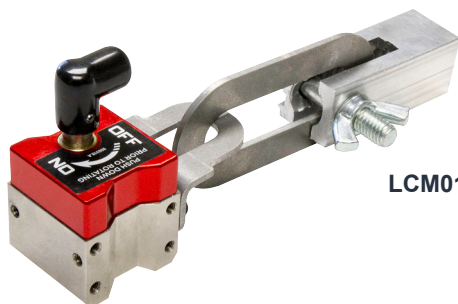
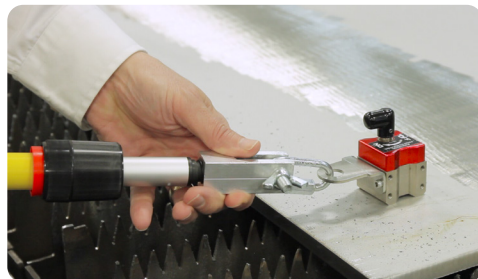

LCM0150-01

LCM0150-02

Hold - lbs (kg)	Pole Included	Length (in)	Extended Length (in)	Weight (lbs)	Model No.
150 (68.04)	No	7	N/A	1.20	LCM0150-01
150 (68.04)	Yes	80	147	2.70	LCM0150-02
450 (204.12)	No	8.50	N/A	4.70	LCM0450-01
450 (204.12)	Yes	83	150	6.20	LCM0450-02
1000 (453.60)	No	9.75	N/A	10.95	LCM1000-01
1000 (453.60)	Yes	87.25	151.25	12.45	LCM1000-02

Note: Magnet connector accepts a standard paint roller handle extension thread.

CUTTING TABLE TOOLS & RETRIEVERS

RAPIDFIRE RETRIEVER®



FEATURES:

- » Retrieve hot parts off cutting tables with speed & precision!
- » Increase production while reducing the potential for injury
- » Powerful Rare Earth Magnet holds part securely
- » "On-Command" release with just a quick blast of shop air
- » Actuate release with just one finger, it's as simple as the pull of a trigger



Lift - lbs (kg)	Dia. (in)	Length (in)	Weight (lbs)	Model No.
35.0 (15.88)	3	24	2.1	RFR2400
35.0 (15.88)	3	36	2.3	RFR3600
35.0 (15.88)	3	48	2.5	RFR4800
16.0 (7.40)	1.5	7	0.5	RFR7-15
35.0 (15.88)	3	7	0.8	RFR7-30

ON/OFF POWER GRIP

FEATURES:

- » Switchable Rare Earth Magnet
- » Securely grips heavy parts
- » Works on flat or pipe
- » Max. Temp. 180°F (82°C)
- » Locking On/Off Handle
- » Comfort Grip

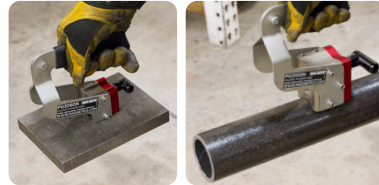

Flat Lift - lbs (kg)	Round Lift - lbs (kg)	Ht. (in)	Wd. (in)	Ln (in)	Magnet Wd. (in)	Magnet Ln (in)	Wt. (lbs)	Model No.
60 (27.22)	30 (13.61)	5	2	6	1-1/2	1-1/4	1.65	PG3060N
100 (45.36)	50 (22.68)	7-3/4	3-3/8	7-1/2	2-1/2	2	5.65	PG3100N

Lift value on pipe varies based on diameter and wall thickness.

POWER GRIP



Our Power Grip Plus sports a light-weight, non-conductive nylon handle and has an easy, side-roll release feature. It's available in three different types of magnetic material for a variety of affordable options based on magnetic strength and/or heat tolerance.

FEATURES:

- » Effective holding against shear force
- » Securely grips heavy parts
- » Maximum Temp. 300°F (148°C)



Magnet Height 1"

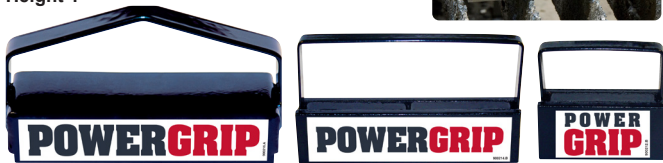

Lift - lbs (kg)	Ht. (in)	Wd. (in)	Ln. (in)	Poles	Wt. (lbs)	Model No.
25.0 (11.34)	2	3/4	2-1/8	2	0.40	AC2100WLH
51.5 (23.36)	2-1/4	3/4	4	2	0.75	AC2200WLH
92.5 (41.96)	2-3/4	1-7/8	5-1/4	4	1.80	AC2201WLH

MAGNETIC TRIGGERLIFT®



Hand held lift allows strong grip of parts with an easy to use trigger release. The new molded plastic design provide better ergonomics and easier release.

FEATURES:

- » Retrieve hot parts from cutting tables
- » One handed operation
- » Permanent magnet
- » Move parts faster and easier
- » Plastic injection molded body and trigger
- » Maximum Temp. 300°F (148°C)



Lift - lbs (kg)	Height (in)	Width (in)	Length (in)	Weight (lbs)	Model No.
36 (16.33)	6"	2-3/4	4-1/8	.90	B090

GRIP STICK RETRIEVER



FEATURES:

- » Reduce employee injury by keeping hands out of press
- » Magnet & Grip ends are interchangeable.
- » Retrieve hot parts
- » 10° angled handle



Lift - lbs (kg)	Type	Ht. (in)	Wd. (in)	Ln. (in)	Wt. (lbs)	Model No.
12.5 (5.67)	Low Profile	7/8	1-3/8	14	0.65	IMPL2100
43.5 (19.73)	Low Profile	7/8	1-3/8	14	0.65	IMPL2104
40.0 (18.14)	Heavy Duty	1-7/8	7/8	14	0.90	IMPL3040
60.0 (27.21)	Heavy Duty	1-7/8	1-7/8	14	1.05	IMPL3060

POWER GRIP PLUS



FEATURES:

- » Securely grips heavy/hot/sharp parts
- » Lightweight, non-conductive nylon handle
- » Easy side-roll release
- » Maximum Temp: Ceramic 300°F (148°C), Neodymium 180°F (82°C), Samarium Cobalt 392°F (200°C)

Note: Magnet Length 6", Magnet Width 0.56"

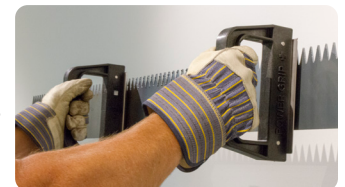

Lift - lbs (kg)	Magnet Type	Ht. (in)	Wd. (in)	Ln. (in)	Wt. (lbs)	Model No.
50 (22.68)	Ceramic	5	2.17	7.5	2.6	PG2050C
180 (81.65)	Neodymium	5	2.17	7.5	2.6	PG2180N
110 (49.90)	Samarium	5	2.17	7.5	2.6	PG2110S

PERMANENT CERAMIC MAGNETIC LIFTS

BASICLIFT™ MAGNETS



The BasicLift™ is a powerful, no frills permanent ceramic lift magnet perfect for basic flat steel lifting, angle iron, square tubes, etc. Featuring a lightweight and durable Stainless Steel design, the BasicLift™ has a full width cam to release the magnet from the steel surface and a tall lift lug for easy use with crane hooks and slings. The BasicLift™ offers a good value for your dollar with strong lifting capacity and basic lifting features.

FEATURES:

- » Lightweight Design
- » Durable Stainless Steel Casing
- » Large Lift Lug
- » Full Width Cam Release
- » Heat resistant up to 300°F (148°C)
- » 2:1 Design Factor



Model No.	WLL		Overall				Magnet				Bail Opening			Weight (lbs)
	LBS	KG	Height (in)	Width (in)	Length (in)	Handle Length (in)	Height (in)	Width (in)	Length (in)	No. of Poles	Thickness (in)	Height (in)	Width (in)	
BL0400	400	181	5-1/2	5-5/8	7-1/2	12	1-5/8	4-1/2	3	4	1/4	2-3/4	2-3/4	11
BL1000	1000	453	5-1/2	5-5/8	11	12	1-5/8	4-1/2	6-1/2	8	1/4	2-3/4	2-3/4	17
BL1500	1500	680	5-1/2	5-5/8	14-1/2	12	1-5/8	4-1/2	10	12	1/4	2-3/4	2-3/4	24

Working Load Limit (WLL) in lbs (kg) & *Maximum Sheet Length Due To Sag For Material Thickness For Single Magnet Use								
Model No.	3/16" (6' Length)	1/4" (6' Length)	3/8" (8' Length)	1/2" (8' Length)	3/4" (8' Length)	1" (10' Length)	3" (10' Length)	
BL0400	375 (170)	400 (181)	400 (181)	400 (181)	400 (181)	400 (181)	400 (181)	
BL1000	725 (328)	800 (362)	875 (396)	975 (442)	1000 (453)	1000 (453)	1000 (453)	
BL1500	875 (396)	1000 (453)	1400 (635)	1400 (635)	1500 (680)	1500 (680)	1500 (680)	

NOTE: Working Load Limit (WLL) lifting values for the BasicLift™ Magnets are stated at 50% of the actual value. We recommend when lifting sheets over 8', use 2 or more lifts on a spreader bar to prevent sheet flexing, sagging or peel-off. Thin material is susceptible to magnetic bleed through, resulting in two sheets being lifted at once. *These maximum sheet lengths are selected due to the sag characteristics of the specified sheet. The item to be lifted must cover the entire length and width of the magnetic poles to properly engage and release the part.

CREATIVE LIFT® MAGNETS



Permanent lift magnets are ideal for handling steel plates, die castings, forgings, etc. They eliminate the need for clamping devices, slings or chains. One person can perform operations previously calling for two or more people.

FEATURES:

- » The original Non-Marring Roller Cam Release will easily release parts without gouging your valuable materials
- » Spring return handle
- » Less torque required to release load
- » "Jack Screw" Secondary Release
- » Lift capacity clearly stated on magnet
- » Durable Stainless Steel Casing
- » Heat Resistant up to 300°F (148°C)
- » 3:1 Design Factor
- » ASME B30.20 BTH-1 Design Category B Service Class 3



Model No.	WLL		Overall				Magnet				Bail Opening			Weight (lbs)
	LBS	KG	Height (in)	Width (in)	Length (in)	Handle Length (in)	Height (in)	Width (in)	Length (in)	No. of Poles	Thickness (in)	Height (in)	Width (in)	
CL0400	400	181	6-3/4	7-1/4	7-3/4	16	2-1/2	6-1/2	4	4	3/8	2-7/8	3	21
CL1000	1000	453	6-3/4	7-1/4	10-3/4	16	2-1/2	6-1/2	7	8	3/8	2-7/8	3	33
CL1500	1500	680	6-3/4	7-1/4	14-3/4	16	2-1/2	6-1/2	10-1/2	12	3/8	2-7/8	3	46
CL2200	2200	998	7	10-1/2	15	16	2-1/2	9-3/4	11-1/4	12	3/8	2-7/8	3	69
CL3000	3000	1360	7	10-1/2	19-1/4	16	2-1/2	9-3/4	15-1/4	17	3/8	2-7/8	3	92

Working Load Limit (WLL) in lbs (kg) & *Maximum Sheet Length Due To Sag For Material Thickness For Single Magnet Use								
Model No.	3/16" (6' Length)	1/4" (6' Length)	3/8" (8' Length)	1/2" (8' Length)	3/4" (8' Length)	1" (10' Length)	3" (10' Length)	
CL0400	400 (181)	400 (181)	400 (181)	400 (181)	400 (181)	400 (181)	400 (181)	
CL1000	600 (272)	900 (408)	1000 (453)	1000 (453)	1000 (453)	1000 (453)	1000 (453)	
CL1500	800 (362)	1000 (453)	1500 (680)	1500 (680)	1500 (680)	1500 (680)	1500 (680)	
CL2200	800 (362)	1064 (482)	1725 (782)	2000 (907)	2000 (907)	2200 (998)	2200 (998)	
CL3000	800 (362)	1100 (498)	1800 (816)	2700 (1224)	3000 (1360)	3000 (1360)	3000 (1360)	

NOTE: Working Load Limit (WLL) lifting values for the Creative Lift® Magnets are stated at 33% of the actual value. We recommend when lifting sheets over 8', use 2 or more lifts on a spreader bar to prevent sheet flexing, sagging or peel-off. Thin material is susceptible to magnetic bleed through, resulting in two sheets being lifted at once. *These maximum sheet lengths are selected due to the sag characteristics of the specified sheet. The item to be lifted must cover the entire length and width of the magnetic poles to properly engage and release the part.

PERMANENT RARE EARTH MAGNETIC LIFTS

POWERLIFT® MAGNETS

These compact switchable Rare Earth permanent lift magnets can be used on flat or round surfaces and contain an internal release On/Off device that does not contact or damage the surface of the part being lifted. Permanent magnetic lifts eliminate the fear of dropping the load being lifted due to power failures. The locking system is performed by first pulling on the handle to release the lock pin, then rotating the handle to the desired position. The locking feature prevents the handle from being bumped partially "On" and avoids giving the operator a false feeling that the magnet is holding safely.

FEATURES:

- » On/Off Rare Earth Permanent Magnet
- » Handle locks in both On and Off position
- » Lifts flat or round loads (see chart below)
- » Easy internal manual release does not contact the load
- » Heat resistant up to 180°F (82°C)
- » 3:1 Design Factor
- » ASME B30.20 BTH-1 Design Category B Service Class 3



Picture above right: A customized version of IMI's Vertical Lift Adaptor featuring two PowerLift® magnets, designed to lift ferrous metal from horizontal to vertical orientation or vice versa. Adjustable for various widths, thicknesses and shapes. Ask for a PowerLift Tech Sheet for specifications.



See Special Utility Applications Lifters in IMI's 101z Catalog

	WLL		Overall		Magnet			Handle		Bail			
Model No.	LBS	KG	Height (in)	Length (in)	Height (in)	Width (in)	Length (in)	Length (in)	Thickness (in)	Height (in)	Width (in)	Weight (lbs)	
PNL0250	250	113	6-5/8	5	2-5/8	2-5/8	3-5/8	4	3/16	1-3/8	1-1/2	6	
PNL0800	800	363	8-7/8	7-7/8	3-7/8	3-5/8	6-3/8	8	1/2	2-3/8	1-3/4	21	
PNL1600	1600	726	8-7/8	10-3/4	4-3/4	4-7/8	9-1/8	9	5/8	3-1/2	2-1/4	51	
PNL2500	2500	1134	13-3/8	12-5/8	6-1/2	7-1/8	10-5/8	10-3/4	3/4	4-3/4	3-3/4	122	
PNL5000	5000	2268	18	16-1/2	8-3/8	9-1/4	14-7/8	16-3/4	7/8	6	4-3/4	288	
PNL6600	6600	2993	22-1/4	20	10-1/4	11-1/4	18-1/16	20-5/8	1-7/16	7-1/4	5-3/4	485	

Working Load Limit (WLL) in lbs (kg) & *Max Sheet Length Due To Sag For Material Thickness For Single Magnet Use

Model No.	Working Load Limit (WLL) in lbs (kg) & *Max Sheet Length Due To Sag For Material Thickness For Single Magnet Use								Round Lifting Applications		
	1/4" (6' Ln)	3/8" (8' Ln)	1/2" (8' Ln)	3/4" (8' Ln)	1" (10' Ln)	2" (10' Ln)	3" (10' Ln Length)	WLL - lbs (kg)	Min. Dia. (in)	Min. Th. (in)	
PNL0250	180 (81)	250 (113)	250 (113)	250 (113)	250 (113)	250 (113)	250 (113)	125 (57)	2	1/2	
PNL0800	270 (122)	500 (226)	615 (279)	800 (362)	800 (363)	800 (363)	800 (362)	400 (181)	3	1/2	
PNL1600	NA	CF	800 (362)	1600 (726)	1600 (726)	1600 (726)	1600 (726)	800 (362)	4	1	
PNL2500	NA	NA	CF	CF	1490 (675)	2500 (1134)	2500 (1134)	1250 (567)	5	2	
PNL5000	NA	NA	NA	NA	CF	2625 (1190)	5000 (2268)	2500 (1134)	14	4	
PNL6600	NA	NA	NA	NA	NA	NA	6600 (2993)	3300 (1496)	CF	CF	

NOTE: Working Load Limit (WLL) lifting values for the PowerLift® Magnets are stated at 33% of the actual value. We recommend when lifting sheets over 8', use 2 or more lifts on a spreader bar to prevent sheet flexing, sagging or peel-off. This material is susceptible to magnetic bleed through, resulting in two sheets being lifted at once. Round Item Lifting Values are based on ideal conditions. Pipe length, wall thickness, diameter and surface condition can all affect the magnet's performance. Please consult the factory before specifying these magnets for use on round materials. *These maximum sheet lengths are selected due to the sag characteristics of the specified sheet. The item to be lifted must cover the entire length and width of the magnetic poles to properly engage and release the part. CF = Consult Factory NA = Not Applicable (Magnets listed will not turn "ON" on specified material thicknesses.)

PERMANENT RARE EARTH MAGNETIC LIFTS

ADVANTAGELIFT™ MAGNETS

The AdvantageLift™ has many advantages over other lift magnets on the market. This On/Off Permanent Rare Earth Lift magnet built to last in a heavy-duty industrial work environment while providing all the safety features that protect workers and equipment. First, the handle operation is by far the best and most ergonomic feature of the magnet. Handle moves laterally in and out instead of pulling the handle or pressing a release button or lever. While other magnets are not equipped to allow use a "cheater bar" to turn a magnet "On" and "Off," this lift magnet can accommodate a tubular bar or pipe. This reduces the need to bend over to turn the magnet "On" and "Off" when lifting steel off pallets or the floor. Removal of any "cheater bar" or pipe during the lift process is recommended to prevent damage to the handle and other items the bar could encounter. Second, the lifting bail is the "lock-out" feature for this magnet. When magnet is under load, the lifting bail lock-out prevents the handle from being rotated to the Off position. This feature works on the vertical lifting bail as well.

FEATURES:

- » On/Off Permanent Rare Earth Magnet
- » Handle moves laterally instead of pulling, pressing buttons or levers
- » Locking lifting bail(s) prevents accidental load release during lift
- » Recessed (protected) labels for extended life
- » Lifts flats both horizontally and vertically with Vertical Lift Bail
- » Supports custom pole shoes (1/4"-20 Tapped Holes, 1/2" deep)
- » Swiveling Lift Bail(s)
- » Operating temperature range of -10°F (-23°C) to 180°F (82 °C)
- » 3:1 Design Factor
- » ASME B30.20 BTH-1 Design Category B Service Class 3



Model No.	WLL		Overall			Magnet			Handle		Bail			Wt. (lbs)
	LBS	KG	Ht. (in)	Wd. (in)	Ln. (in)	Ht. (in)	Wd.(in)	Ln. (in)	Ln. (in)	Th. (in)	Ht. (in)	Wd. (in)		
AL0660	660	300	8	5-7/16	10-1/8	4-5/8	3-3/8	6-3/16	10-1/8	1/2	1-7/8	1-1/2	33	
AL1200	1200	454	8	5-7/16	13-1/4	4-5/8	3-3/8	9-3/16	10-1/8	1/2	1-7/8	1-1/2	46	
AL1600	1600	680	10	6-7/8	13-5/16	6	4-3/8	9-3/16	11-7/16	5/8	2-7/32	1-3/4	80	
AL2200	2200	907	10	6-7/8	16-5-1/16	6	4-3/8	12-3/16	11-7/16	5/8	2-7/32	1-3/4	102	
ALLUG1	-	-	3-9/16	4-3/8	4-11/16	-	-	-	-	1/2	1-7/8	1-1/2	4	
ALLUG2	-	-	4-3/4	5-3/4	5-3/4	-	-	-	-	5/8	2-7/32	1-3/4	6	

Model No.	Working Load Limit (WLL) in lbs (kg) & *Max Sheet Length Due To Sag For Material Thickness For Single Magnet Use						Round Lifting Applications			WLL Vertical Flat Only				
	1/4" (6' Ln)	3/8" (8' Ln)	1/2" (8' Ln)	3/4" (8' Ln)	1" (10' Ln)	2" (10' Ln)	WLL- lbs (KG) 8"O.D. 1" Th	Min. Dia. (in)	Min. Th. (in)	Model No.	Lbs*	KG*	Length (in)	Weight (lbs)
AL0660	220 (100)	410 (186)	480 (218)	660 (300)	660 (300)	660 (300)	330 (113)	2	1/2	AL0660LUG	165	75	14-7/8	37
AL1200	290 (132)	590 (268)	670 (304)	1200 (544)	1200 (544)	1200 (544)	660 (300)	3	1/2	AL1200LUG	300	136	17-15/16	50
AL1600	340 (154)	670 (304)	770 (349)	1350 (612)	1600 (726)	1600 (726)	800 (362)	4	1	AL1600LUG	400	182	18	86
AL2200	NA	NA	NA	1720 (780)	2200 (998)	2200 (998)	NA	5	2	AL2200LUG	550	250	22	108

*Note: Lift Capacity Based On 1" Minimum Material Thickness

NOTE: Working Load Limit (WLL) lifting values for the AdvantageLift® Magnets are stated at 33% of the actual value. We recommend when lifting sheets over 8', use 2 or more lifts on a spreader bar to prevent sheet flexing, sagging or peel-off. Thin material is susceptible to magnetic bleed through, resulting in two sheets being lifted at once. Round Item Lifting Values are based on ideal conditions. Pipe length, wall thickness, diameter and surface condition can all affect the magnet's performance. Please consult the factory before specifying these magnets for use on round materials. *These maximum sheet lengths are selected due to the sag characteristics of the specified sheet. The item to be lifted must cover the entire length and width of the magnetic poles to properly engage and release the part. **CF = Consult Factory NA = Not Applicable (Magnets listed will not turn "ON" on specified material thicknesses.)**

SPREADER BEAMS



When lifting large steel shapes, such as off-center loads, round, rectangular or long items (I-beams), one lift magnet may not be enough. IMI's Spreader Beams allow two magnets to be used at one time with only one lifting source. Magnets on a Spreader Beam keep your product level, reducing the height required to lift the load, providing a safer lift environment while reducing the time needed to move the load.



SBI SERIES FEATURES:

- » Low cost spreader beams
- » One-piece construction
- » Fork lift pockets
- » Multiple spreads plus center hole
- » Designed and manufactured to ASME B30.20



SBC SERIES FEATURES

- » Beams 3' to 4' have 2 spreads
- » Beams 6' to 10' have 3 spreads
- » Swivel hooks with latches
- » Designed and manufactured to ASME B30.20

PERMANENT RARE EARTH MAGNETIC LIFTS

DYNAMICLIFT™ MAGNETS

These lightweight switchable Rare Earth permanent lift magnets can be used on flat or round surfaces and contain an internal release On/Off device.

FEATURES:

- » Top rotating On/Off actuated Rare Earth permanent magnet
- » Lifts flat or round loads horizontally and flat loads vertically
- » Locking On/Off handle
- » Heat resistant up to 180°F (82°C)
- » 3:1 Design Factor
- » ASME B30.20 BTH-1 Design Category B Service Class 3



Model No.	Working Load Limit		Overall		Magnet			Handle	Bail			
	WLL (lbs)	WLL (kg)	Height (in)	Length (in)	Height (in)	Width (in)	Length (in)	Length (in)	Thick. (in)	Height (in)	Width (in)	Weight (lbs)
DL0150	150	68.04	10	5	2-3/4	2-1/2	3	2-1/2	1/4	2-1/4	3	6.1
DL0334	334	151.50	10-7/16	6-1/2	3	4	4-1/4	2-1/2	1/4	2-1/4	4	13.3

Model No.	Horizontal Flat Part WLL in lbs (kg), Min. Steel Thickness & *Max. Length Due To Sag For Single Magnet							Vertical Part Lift (Flat Only)	
	1/4" (6' Ln)	3/8" (8' Ln)	1/2" (8' Ln)	3/4" (8' Ln)	1" (10' Ln)	2" (10' Ln)	3" (10' Ln)	WLL - lbs (kg)	Min. Thickness
DL0150	150 (68.04)	150 (68.04)	150 (68.04)	150 (68.04)	150 (68.04)	150 (68.04)	150 (68.04)	40 (17.01)	0.25 In.
DL0334	275 (124.73)	320 (145.15)	334(151.49)	334(151.49)	334(151.49)	334(151.49)	334(151.49)	75 (37.88)	0.37 In.

Model No.	Horizontal Round Part Round Lifting Applications			
	Maximum WLL - lbs (kg)	Minimum Diameter	Minimum Wall Thickness	Maximum WLL at Min. Diameter & Min. Thickness
DL0150	75 (34.02)	2	1/8	65 (29.48)
DL0334	167 (75.75)	4	1/8	100 (45.36)

NOTE: Lifting Values for the DynamicLift™ Magnets are stated at 33% of the actual value. We recommend when lifting sheets over 8', use 2 or more lifts on a spreader bar to prevent sheet flexing, sagging or peel-off. Thin material is susceptible to magnetic bleed through, resulting in two sheets being lifted at once. Consult the factory before specifying these magnets for use on round materials. Round Item Lifting Values are based on ideal conditions. Length, wall thickness, diameter and surface can all affect the magnet's performance. *Maximum sheet lengths are selected due to the sag characteristics of the specified sheet. The item to be lifted must cover the entire length and width of the magnetic poles to properly engage and release.

CUSTOM FIXTURE WITH PERMANENT ON/OFF MAGNETS

Our factory experts will develop a unique magnetic lifting device if a standard magnetic lift doesn't work for your application. We will be there every step of the way from field sales support to design, manufacturing and final testing.

For more information on our custom lifting products, please contact us today at 888.582.0823 or go online to www.magnetics.com

- » Custom beams
- » Custom pole shoes
- » Custom lift and rotate fixtures



FX SERIES LIFTING MAGNETS

FX UNIVERSAL PERMANENT LIFTING MAGNETS FOR FLATS AND ROUND



The FX universal, On/Off permanent lift magnets are ideal for a variety of manufacturing applications where you're mostly lifting flat material, but occasionally need to lift rounds.

- » On/off, Rare-Earth Permanent Magnet
- » On/off handle only requires 90° rotation and locks at both on/off positions
- » Durable, recessed metal name plates, not stickers
- » Corrosion resistant, plated-magnet surface
- » Heat resistant up to 180°F (82°C)
- » 3:1 Design Factor
- » 2018 ASME B30.20 BTH-1 Design Category B, Service Class 3

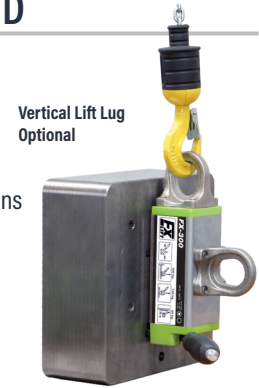

Model No.	WLL		Overall		Magnet			Handle	Bail			
	LBS	KG	Ht. (in)	Ln. (in)	Ht. (in)	Wd. (in)	Ln. (in)	Ln. (in)	Th. (in)	Ht. (in)	Wd. (in)	Wt. (lbs)
FX0330	330	150	4.9	6.3	2.3	2.5	4.75	5.3	0.4	1.6	1	8
FX0660	660	300	6.2	8	3	3.4	6.2	7.5	0.5	2	1.6	19
FX1320	1320	600	7.4	11.3	3.7	4.4	9.4	9	0.6	2.4	2	42
FX2200	2200	1000	9.4	14.2	4.7	6	12	10.2	0.8	3	2.3	93
FX4400	4400	2000	12.3	18.5	6.6	9	15.7	16.1	1	3.5	2.6	254
FX6600	6600	3000	12.3	25.5	6.6	9	22.7	21	1	3.5	2.6	366

Model No.	Working Load Limit (WLL) in lbs (kg) & *Max sheet Length Due To Sag For Material Thickness								Round Lifting Applications			Vertical
	For Single Magnet Use								WLL RD	Min/Max Dia	Min Thk	Part Flat WLL
	1/4 (6')	3/8 (8')	1/2 (8')	3/4 (8')	1 (10')	2 (10')	3 (10')	WLL				
FX0330	142 (65)	330 (150)	330 (150)	330 (150)	330 (150)	330 (150)	330 (150)	165 (75)	2 - 8	5/16	66 (30)	
FX0660	355 (152)	507 (230)	580 (263)	660 (300)	660 (300)	660 (300)	660 (300)	330 (150)	2 - 12	1/2	132 (60)	
FX1320	331(150)	661 (300)	965 (438)	1320 (599)	1320 (599)	1320 (599)	1320 (599)	660 (300)	4 - 16	5/8	264 (120)	
FX2200	NA	772 (350)	1160 (526)	1984 (900)	2200 (998)	2200 (998)	2200 (998)	1100 (500)	4 - 18	3/4	440 (200)	
FX4400	NA	NA	965 (438)	2200 (998)	2646 (1200)	4400 (1996)	4400 (1996)	2200 (998)	6 - 24	1-1/2	NA	
FX6600	NA	NA	NA	3850 (1746)	3968 (1800)	6600 (2994)	6600 (2994)	3300 (1497)	6 - 24	1-1/2	NA	

FXP PERMANENT LIFTING MAGNETS FOR THIN SHEETS AND PIPE



Ideal for thin sheets or parts, tanks/containers and thin-walled pipe that normally can't be lifted with a permanent, On/Off magnet. The magnetic field on the FXP is concentrated and shallow to drive the strength into thin material.

- » On/off Rare Earth Permanent Magnet
- » On/off handle only requires 90° rotation and locks at both on/off positions
- » Recessed metal name plates, not stickers
- » Corrosion resistant, plated-magnet surface
- » Heat resistant up to 180°F (82°C)
- » 3:1 Design Factor
- » 2018 ASME B30.20 BTH-1 Design Category B, Service Class 3



Model No.	WLL		Overall		Magnet			Handle	Bail			
	LBS	KG	Ht. (in)	Ln. (in)	Ht.(in)	Wd. (in)	Ln. (in)	Ln. (in)	Th. (in)	Ht. (in)	Wd. (in)	Wt. (lbs)
FXP0375	375	170	5.3	7.7	2.7	2.5	6.8	5.3	0.4	1.6	1	12
FXP0725	725	330	6.7	10.4	3.5	3.4	9.4	7.5	0.5	2	1.6	28
FXP1450	1450	650	8	13.8	4.2	4.4	12.6	9	0.6	2.4	2	58

Model No.	Working Load Limit (WLL) in lbs (kg) & *Max sheet Length Due To Sag For Material Thickness								Round Lifting Applications		
	For Single Magnet Use								WLL RD	Min/Max Dia	Min Thk
	9 ga (6')	3/16 (6')	1/4 (6')	3/8 (8')	1/2 (8')	3/4 (8')	1 (10')	WLL			
FXP0375	176 (80)	200 (91)	265 (120)	375 (170)	375 (170)	375 (170)	375 (170)	330 (150)	1 - 4	5/16	
FXP0725	220 (100)	275 (125)	353 (160)	725 (329)	725 (329)	725 (329)	725 (329)	660 (300)	2 - 6.5	1/2	
FXP1450	353 (160)	375 (170)	441 (200)	1060 (481)	1125 (510)	1450 (658)	1450 (658)	1210 (550)	3 - 9	5/8	

FX SERIES LIFTING MAGNETS

FXR PERMANENT LIFTING MAGNETS FOR ROUND MATERIAL

The FXR is recommended for when lifting round/curved surfaces such as shafts, thick walled pipe, or billet, but occasionally need to lift flat material. Specially designed pole shoes provide a deep penetrating magnetic field and part stability.

- » On/off, Rare-Earth Permanent Magnet
- » On/off handle only requires 90° rotation and locks at both on/off positions
- » Durable, recessed metal name plates, not stickers
- » Corrosion resistant, plated-magnet surface
- » Heat resistant up to 180°F (82°C)
- » 3:1 Design Factor
- » 2018 ASME B30.20 BTH-1 Design Category B, Service Class 3

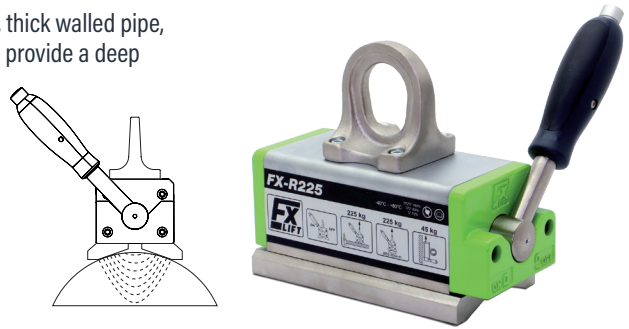

Model No.	WLL		Overall			Magnet		Handle		Bail			Wt.(lbs)
	LBS	KG	Ht. (in)	Ln. (in)	Ht. (in)	Wd. (in)	Ln. (in)	Ln. (in)	Th. (in)	Ht. (in)	Wd. (in)		
FXR0220	220	100	5.2	6.3	2.7	2.7	5.4	5.3	0.4	1.6	1	9	
FXR0500	500	225	6.7	8	3.5	3.8	7.2	7.5	0.5	2	1.6	21	
FXR1000	1000	450	8.1	11.3	4.4	4.9	10.2	9	0.6	2.4	2	49	
FXR1650	1650	750	10.3	14.2	5.6	6.7	13	10.2	0.8	3	2.3	108	
FXR2650	2650	1200	13.1	18.5	7.5	9.7	18.2	16.1	1	3.5	2.6	280	
FXR4000	4000	1800	13.1	25.5	7.5	9.7	24.1	21	1	3.5	2.6	402	

Working Load Limit (WLL) in lbs (kg) & *Max sheet Length Due To Sag For Material Thickness								Round Lifting Applications		
For Single Magnet Use								WLL RD	Min/Max Dia	Min Thk
Model No.	1/4 (6')	3/8 (8')	1/2 (8')	3/4 (8')	1 (10')	2 (10')	3 (10')			
FXR0220	154 (70)	220 (100)	220 (100)	220 (100)	220 (100)	220 (100)	220 (100)	220 (100)	1 - 6	5/16
FXR0500	310 (141)	500 (227)	500 (227)	500 (227)	500 (227)	500 (227)	500 (227)	500 (225)	2 - 8	3/8
FXR1000	331 (150)	661 (300)	780 (354)	1000 (454)	1000 (454)	1000 (454)	1000 (454)	1000 (450)	2 - 11	3/4
FXR1650	NA	882 (400)	1200 (544)	1650 (748)	1650 (748)	1650 (748)	1650 (748)	1650 (750)	3 - 15	3/4
FXR2650	NA	450 (204)	900 (408)	1764 (800)	2205 (1000)	2650 (1202)	2650 (1202)	2650 (1200)	5 - 22	1-1/2
FXR4000	NA	NA	1250 (567)	2646 (1200)	3307 (1500)	4000 (1814)	4000 (1814)	4000 (1800)	5 - 22	1-1/2

FXV PERMANENT LIFTING MAGNETS FOR BEAMS, ANGLE IRON (90°) AND HOT PARTS

The FXV On/Off permanent lift magnets are ideal for handling 90° shapes like angle iron, square tubing, and hot parts. Also works extremely well for inside webbing of I-beams where you need higher handle rotation. The on/off handle only requires 90° rotation and locks at both on/off positions. Durable construction with recessed metal name plates and corrosion-resistant plated magnet surface. Features a 3:1 design factor and meets 2018 ASME B30.20 BTH-1 Design Category B, Service Class 3.

Hot part Handling: contact time and cooling times

- 302°F (150°C) = 100%
 - 392°F (200°C) = 50%, Max. 4 minutes contact, 4 minutes cooling time
 - 482°F (250°C) = 33%, Max. 4 minutes contact, 8 minutes cooling time
- (Note: WLL reduces as temperature raises)



Model No.	WLL		Overall			Magnet		Handle		Bail			Wt. (lbs)
	LBS	KG	Ht. (in)	Ln. (in)	Ht. (in)	Wd. (in)	Ln. (in)	Ln. (in)	Th. (in)	Ht. (in)	Wd. (in)		
FXV0440	440	220	5.5	7.7	3	2.5	6.8	5.3	0.4	1.6	1	12	
FXV0880	880	440	6.9	10.4	3.8	3.4	9.4	7.5	0.5	2	1.6	29	
FXV1775	1775	800	8.3	13.5	4.5	4.4	12.6	9	0.6	2.4	2	62	

FLAT SURFACES						ANGLE IRON LEGS DOWN (Λ) ANGLE LEGS UP (V)											
Working Load Limit (WLL) in lbs (kg) & *Max sheet Length Due To Sag For Material Thickness For Single Magnet Use						Λ		V		Λ		V		Λ		V	
Model No.	1/4 (6')	3/8 (8')	1/2 (8')	3/4 (8')	1 (10')	Model No.	1/4 (6')	1/4 (6')	3/8 (8')	3/8 (8')	1/2 (8')	1/2 (8')	3/4 (8')	3/4 (8')	1 (14')	1 (14')	
FXV0440	270	415	440	440	440	FXV0440	260	100	260	175	260	220	260	220	260	220	
	(125)	(190)	(200)	(200)	(200)		(120)	(50)	(120)	(80)	(120)	(100)	(120)	(100)	(120)	(100)	
FXV0880	440	695	810	880	880	FXV0880	440	270	495	275	550	385	550	440	550	440	
	(200)	(320)	(370)	(400)	(400)		(200)	(125)	(225)	(125)	(250)	(175)	(250)	(200)	(250)	(200)	
FXV1775	440	935	1150	1775	1775	FXV1775	485	300	650	325	815	500	870	650	870	650	
	(200)	(450)	(550)	(800)	(800)		(220)	(140)	(300)	(150)	(375)	(230)	(400)	(300)	(400)	(300)	

FXC PERMANENT LIFTING MAGNETS FOR FLAT, CIRCULAR PARTS

The FXC lift magnets have a round, multi-pole magnetic field designed for lifting flat, circular-shaped parts such as rings, sleeves, bearing housings, flange plates and end of billet/pipe/shaft pieces. The on/off handle only requires 90° rotation and locks at both on/off positions. Durable construction with metal name plates and corrosion-resistant plated magnet surface. Features a 3:1 design factor and meets 2018 ASME B30.20 BTH-1 Design Category B, Service Class 3.

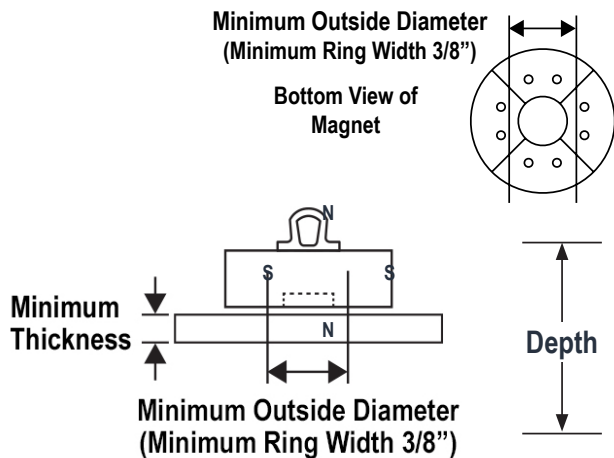

Model No.	WLL		WLL	WLL	Overall		Depth	Magnet		Handle	Bail			Wt. (lbs)
	LBS	KG	Min Thk (in)	Min Dia (in)	Ht. (in)	Dia. (in)	Ht. (in)	Ht. (in)	Dia. (in)	Ln. (in)	Th. (in)	Ht. (in)	Wd. (in)	
FXC0385	385	175	0.39	2.4	8.3	4.7	5	5.1	4.5	7.5	0.5	2	1.6	17
FXC0550	550	250	0.47	3.3	9.5	6.3	5.8	5.7	6	7.5	0.6	2.4	2	33
FXC0990	990	450	0.59	4.7	11.2	9.4	6.5	6.1	9.3	9	0.8	3	2.3	77

CUSTOM FIXTURE WITH PERMANENT ON/OFF MAGNETS

Our factory experts will develop a unique magnetic lifting device if a standard magnetic lift doesn't work for your application. We will be there every step of the way from field sales support to design, manufacturing and final testing.

For more information on our custom lifting products, please contact us today at 888.582.0823 or go online to www.magnetics.com

- » Custom beams
- » Custom pole shoes
- » Custom lift and rotate fixtures

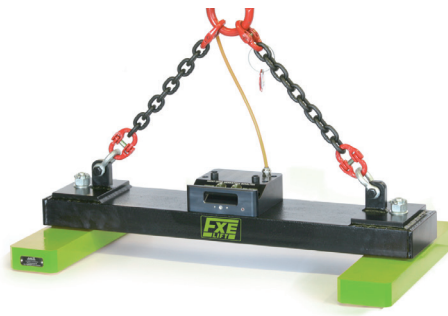

FX SERIES LIFTING MAGNETS

FXE PERMANENT LIFTING MAGNETS ELECTRONICALLY CONTROLLED

FXE lift magnets allow the operator to pick-up ferrous metal sheets/parts and safely release with the push of a button. Combining the cost-efficiency and safety of a permanent magnet for load handling with the controlled-release capability of an electromagnet, the FXE uses virtually no energy and does not require a battery backup system. A built-in load sensor prevents the load from being released until it's at rest, and the fail-safe permanent magnet design securely holds the load in the event power is lost. Ideal for lifting applications that require fast cycle times without the operator touching the load. Grip and release functions can be performed by using the wireless remote control or can be activated directly from the magnet's on-board control buttons. All labels and controls are on top of the magnet allowing the magnet to fit into tight spots and limit damage to critical equipment. Temperature Range: 180°F (82°C)

Quick Reference

- 50 Series: Smooth surfaces • Smaller parts • Cutting table loading/unloading • Thinner metals
- 50L Series: Smooth Surfaces • Long narrow parts • C channel • I-Beam • Square tubing
- 80 Series: Hot rolled steel • Black material • Flame cut • Shipyards • Thicker metals than 50 Series
- 100 Series: Rough surfaces • Casting • Forging • Slabs • Thick, heavy, large metals



4' Curly cord expands to 16' for fast hoist operation.
Cord is 12awg/3 conductor, heavy-duty construction.
Twist-lock connector set provided.

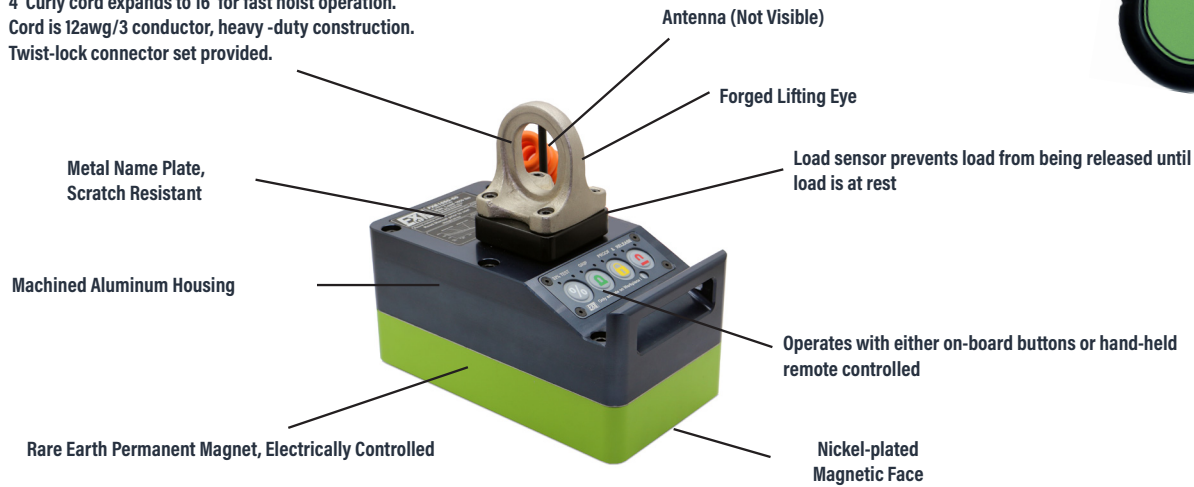

FXE LIFTING MAGNET - 50 SERIES

The FXE50 Series Permanent Lifting Magnet is designed with the strength and reach-out required for lifting thinner, smooth-surfaced material in applications such as the loading and unloading of cutting tables. Ideal for smaller part handling in repetitive lifting applications, this durable magnet is constructed for many years of industrial use. **480 VAC single phase power supply required @ up to 7.5 amps, 0.8 second pulse**

» 2018 ASME B30.20 BTH-1 Design Category B, Service Class 3



FXE0660-50



FXE1650-50



FXE3525-50

50 Series	WLL		Magnet		Overall			Poles	Bail Opening			Weight
Model No.	LBS	KG	Ln. (in)	Wd. (in)	Ln. (in)	Wd. (in)	Ht. (in)	No. of Poles	Th. (in)	Ht. (in)	Wd. (in)	lbs (kg)
FXE0660-50	660	300	4.6	4.6	6.5	6.5	16.5	4	0.6	1.7	1.3	51 (23)
FXE1650-50	1650	750	9.6	4.6	11.7	6.5	9.8	8	0.6	3	2.4	60 (27)
FXE3525-50	3525	1600	22.2	4.6	24.4	6.5	10.6	18	0.8	3	2.4	124 (56)

Working Load Limit (WLL) in lbs (kg) & Max sheet size Due To Sag For Material Thickness For Single Magnet Use

Model No.	5/32 (4mm)	Sheet LxW	1/4 (6mm)	Sheet LxW	5/16 (8mm)	Sheet LxW	3/8 (10mm)	Sheet LxW	1/2 (15mm)	Sheet LxW
FXE0660-50	154 (70)	71" x 59"	309 (140)	79" x 59"	440 (200)	79" x 59"	617 (280)	79" x 59"	660 (299)	79" x 59"
FXE1650-50	330 (150)	71" x 59"	551 (250)	79" x 59"	882 (400)	79" x 59"	1323 (600)	79" x 59"	1650 (748)	79" x 59"
FXE3525-50	661 (300)	118" x 59"	1102 (500)	118" x 59"	1764 (800)	118" x 59"	3087 (1400)	118" x 59"	3525 (1599)	118" x 79"

FX SERIES LIFTING MAGNETS

FXE LIFTING MAGNET - 50L SERIES

The FXE50L Series Permanent Lifting Magnet is designed with the strength and reach-out required for lifting thinner, smooth-surfaced material in applications lifting long narrow products such as C-Channel, I-Beams or square tubing. Ideal for smaller/narrow part handling in repetitive lifting applications. Can use the side of the magnet to rotate or tip parts to the ideal lifting surface or orientation. **480 VAC single phase power supply required @ up to 7.5 amps, 0.8 second pulse**

» 2018 ASME B30.20 BTH-1 Design Category B, Service Class 3



FXE0880-50L



FXE1320-50L



FXE2200-50L



80 Series	WLL		Magnet		Overall			Poles	Bail Opening			Weight
Model No.	LBS	KG	Ln. (in)	Wd. (in)	Ln. (in)	Wd. (in)	Ht. (in)	No. of Poles	Th. (in)	Ht. (in)	Wd. (in)	lbs (kg)
FXE0880-50L	880	400	9.5	2	11.5	3.75	17.75	4	.75	2.25	1.87	51 (23)
FXE1320-50L	1320	6000	14.6	2	16.5	3.75	17.75	8	.75	2.25	1.87	68 (31)
FXE2200-50L	2200	1000	24.7	2	26.8	3.75	17.75	10	.75	2.25	1.87	97 (44)

Working Load Limit (WLL) in lbs (kg) & Max sheet size Due To Sag For Material Thickness For Single Magnet Use

Model No.	5/16 (8mm)	Sheet LxW	3/8 (10mm)	Sheet LxW	1/2 (15mm)	Sheet LxW	3/4 (20mm)	Sheet LxW	1 (25mm)	Sheet LxW
FXE0880-50L	154 (70)	71" x 39"	309 (140)	79" x 59"	440 (200)	79" x 39"	550 (250)	98" x 39"	880 (400)	118" x 39"
FXE1320-50L	220 (100)	79" x 39"	440 (200)	98" x 39"	660 (300)	98" x 39"	770 (350)	118" x 39"	1320 (600)	157" x 39"
FXE2200-50L	330 (150)	98" x 59"	660 (300)	118" x 59"	880 (400)	118" x 39"	1100 (500)	157" x 59"	2200 (1000)	196" x 59"

FXE LIFTING MAGNET - 80 SERIES

The FXE80 Series Permanent Lifting Magnet has great strength for lifting heavier material in applications typically seen in shipyard or heavy equipment manufacturing. Ideal for handling black material, flame-cut, or hot-rolled steel, this durable magnet is constructed for many years of industrial use. **480 VAC single phase power supply required @ up to 10 amps, 0.8 second pulse**

» 2018 ASME B30.20 BTH-1 Design Category B, Service Class 3



FXE2200-80



FXE5500-80



FXE8800-80

80 Series	WLL		Magnet		Overall			Poles	Bail Opening			Weight
Model No.	LBS	KG	Ln. (in)	Wd. (in)	Ln. (in)	Wd. (in)	Ht. (in)	No. of Poles	Th. (in)	Ht. (in)	Wd. (in)	lbs (kg)
FXE2200-80	2200	1000	6.8	6.8	9	9.0	11.6	4	1.2	3	2.4	86 (39)
FXE5500-80	5500	2500	17.6	6.8	20	9.0	11.6	10	1.2	3.5	2.7	170 (77)
FXE8800-80	8800	4000	28.5	6.8	30.8	9.0	11.6	16	0.9	7.9	5.5	291 (132)

Working Load Limit (WLL) in lbs (kg) & Max sheet size Due To Sag For Material Thickness For Single Magnet Use

Model No.	5/16 (8mm)	Sheet LxW	3/8 (10mm)	Sheet LxW	1/2 (15mm)	Sheet LxW	3/4 (20mm)	Sheet LxW	1 (25mm)	Sheet LxW
FXE2200-80	440 (200)	79" x 59"	660 (300)	79" x 59"	1320 (600)	79" x 59"	1760 (800)	79" x 59"	2200 (1000)	79" x 59"
FXE5500-80	1100 (500)	79" x 59"	1650 (750)	118" x 59"	3300 (1500)	118" x 59"	4400 (2000)	118" x 59"	5500 (2495)	118" x 59"
FXE8800-80	1765 (800)	118" x 59"	2650 (1200)	118" x 59"	5290 (2400)	118" x 59"	6600 (3000)	157" x 59"	8800 (3992)	157" x 59"

FX SERIES LIFTING MAGNETS

FXE 100 SERIES FOR THICK, ROUGH PLATES, CASTING & FORGING FXE LIFTING MAGNET - 100 SERIES

The 100 Series Permanent Lifting Magnet has tremendous strength and reach-out for lifting heavier, rough material. Ideal for handling foundry-made or rough-surfaced parts, such as castings, forgings or large slab steel. Durable construction for many years of industrial use. **480 VAC single phase power supply required @ up to 33 amps, 0.8 second pulse**
2018 ASME B30.20 BTH-1 Design Category B, Service Class 3



FXE3525-100



FXE7000-100



FXE10600-100

100 Series	WLL		Magnet		Overall			Poles No. of Poles	Bail Opening			Weight
Model No.	LBS	KG	Ln. (in)	Wd. (in)	Ln. (in)	Wd. (in)	Ht. (in)		Th. (in)	Ht. (in)	Wd. (in)	lbs (kg)
FXE3525-100	3525	1600	8.7	8.7	11.7	11.7	13.6	4	1.2	3.5	2.7	181 (82)
FXE7000-100	7000	3200	18.1	8.7	21.1	11.7	13.2	8	1.2	3.5	2.7	340 (154)
FXE10600-100	10600	4800	27.6	8.7	30.6	11.7	15.8	12	0.9	7.9	5.5	445 (202)

Working Load Limit (WLL) in lbs (kg) & Max sheet size Due To Sag For Material Thickness For Single Magnet Use

Model No.	3/8 (10mm)	Sheet LxW	1/2 (15mm)	Sheet LxW	3/4 (20mm)	Sheet LxW	1 (25mm)	Sheet LxW	1-3/8 (35mm)	Sheet LxW
FXE3525-100	880 (400)	79" x 59"	1650 (750)	79" x 59"	2200 (1000)	79" x 59"	3300 (1500)	118" x 59"	3527 (1600)	118" x 59"
FXE7000-100	1760 (800)	118" x 59"	3200 (1470)	118" x 59"	4850 (2200)	118" x 79"	6125 (2780)	118" x 79"	7000 (3200)	157" x 98"
FXE10600-100	2650 (1200)	118" x 59"	4850 (2200)	157" x 79"	6600 (3000)	158" x 79"	9250 (4200)	157" x 79"	10,600 (4800)	157" x 79"

AUTOMATIC LIFTING MAGNET

Innovative, compact and user-friendly, this magnetic lifting equipment features a strong permanent magnet that is switched between the "ON" and "OFF" states with an electrical pulse.

This permanent lift magnet uses an electronic impulse ONLY to change the magnet from on to off and vice-versa. No electrical power is used during the lifting process. The result of this technology is safe and reliable lifting with long and efficient operation without interruption - over one thousand lifts with one complete, 2 hour battery charge!

The real beauty of this magnet is that it is fully automatic - no user interface is required to turn the magnet ON or OFF. The secret lies in the built-in load-sensing system. This unique feature utilizes a self-adjusting shaft that turns the magnet ON or OFF every time it completes a cycle. When the magnet is set down on a load, the shaft goes down, which engages the magnet. The magnet turns "ON" and stays "ON" until the load is set back down, whereby the shaft goes down and turns the magnet "OFF". The operator also has the option to manually control the magnet by pressing the push buttons located on the side of the unit.

FEATURES:

- » Rare Earth Permanent magnet
- » Automatic controlled ON/OFF
- » Operating Temp: 32°F to 122°F
- » Internal chargeable battery for switching
- » Fast cycle times
- » Over one thousand lifts with one complete battery charge
- » 3:1 design factor
- » 3/8" or thicker does not double blank



Model No.	Working Load Limit (WLL)		Overall				Bail			Weight (lbs)
	WLL (lbs)	WLL (kg)	Height (in)	Width (in)	Length (in)	Thickness (in)	Height (in)	Width (in)		
LI-120ALM	265	120	7.87	4.92	4.92	3/8	1-1/4	1-1/4	14.3	

Working Load Limit in lbs (kg) & *Max Sheet Length Due To Sag For Material Thickness For Single Magnet Use

Model No.	3/16" (6' Length)	1/4" (6' Length)	3/8" (8' Length)	1/2" (8' Length)	1" (10' Length)	3" (10' Length)
LI-120ALM	78 (35)	111 (50)	232 (105)	265 (120)	265 (120)	265 (120)

NOTE: Lifting Values for the Ixtur® Automatic Lift Magnet are stated at 33% of the actual value. We recommend when lifting sheets over 8', use 2 or more lifts on a spreader bar to prevent sheet flexing, sagging or peel-off. Thin material is susceptible to magnetic bleed through, resulting in two sheets being lifted at once. *These maximum sheet lengths are selected due to the sag characteristics of the specified sheet. The item to be lifted must cover the entire length and width of the magnetic poles to properly engage and release the part.

WALKER LIFTING MAGNETS

BUXF BATTERY LIFT MAGNET (FOR FLAT MATERIAL)



These magnets are compact, mobile, self-contained using a heavy duty 12 volt battery. Operating on this battery source they are free of restrictive cords and wires. They also have the added advantage of being useful in areas where electricity is not available.

3:1 Design Factor. 2018 ASME B30.20 BTH-1 Design Category B, Service Class 3

FEATURES:

- » Convenient operator push buttons and battery level display on front panel
- » I/R remote that operates from up to 15 feet away
 - » Single button "GRIP"; two-button "RELEASE" operation
 - » I/R remote clip allows operators to attach to belt or pocket
 - » Additional remote control units available at nominal cost
- » 120 Volt AC battery charging port (with cord) includes automatic cut-off to prevent over-charging battery
- » Audible warning alarm & flashing light indicate low battery
- » Electronic interlock prevents magnet de-energization when suspended in air



WLL - lbs	Overall Length (in)	Magnet Width (in)	Overall Height (in)	Weight w/ Batt. (lbs)	Model No.
3000	21	8-7/8	24-7/8	315	BUXF03000
5500	21	9-5/8	24-7/8	371	BUXF05500
8000	48	9-5/8	25-7/8	688	BUXF08000
11000	60	9-5/8	26-5/8	827	BUXF11000



BUXR BATTERY LIFT MAGNET (FOR FLAT, ROUND OR SHAPED MATERIAL)



The special feature of this battery bi-polar magnet is the unique design of the pole shoe, that enables it to handle a wide variety of structural shapes and rounds.

The BUXR Series Magnet is ideally suited for handling pipe, tubing, bar stock, billets, I beams, H beams, angles, channel, Tees, Zees and pilings. Although the BUXR is specially designed to handle structural shapes and rounds, the bi-polar configuration also lifts plate, forgings and castings. BUXR01665 & BUXR03330 lifting magnets are ideal for loads with a thickness of 1/4" or greater, and diameters between 1 inch and 12 inches.



Rated Lift* (lbs)	Overall Length (in)	Magnet Width (in)	Overall Height (in)	Weight w/Batt (lbs)	Model No.
1665	21	9-1/2	30-1/8	461	BUXR01665
3330	30	10-1/2	32-1/2	821	BUXR03330

Consult Operator's Manual, Safety Instructions & Lifting Guidelines for detailed ratings

WALKER LIFTING MAGNETS

CER ELECTRIC LIFT MAGNET



CER magnets are ideally suited for in-plant handling of steel plate, flat stock, castings, forgings or machined components in all types of industrial plants, machine shops, fabricating shops and steel warehouses.

STANDARD FEATURES:

- » Recessed "GRIP-PROOF-RELEASE" push buttons on unit are protected against accidental operation
- » Low-carbon steel body for maximum magnetic performance
- » Built-in solid-state control circuitry permits operation from 120 Volt AC outlet with 50% duty cycle
- » I/R remote that operates from up to 15 feet away
 - » Two button "PROOF-GRIP"; two-button "PROOF-RELEASE" operation
 - » I/R remote clip allows operators to attach to belt or pocket
 - » Additional remote control units available at nominal cost
- » Flexible coil cord with twist-lock 120 Volt AC plug set supplied standard
- » CER emergency battery backup options available – consult Walker Magnetics

OPTIONS:

- » Rectifier-only models available (no controls) - Controlled by user's AC power supply.
- » Pilot light provided in terminal box for magnet energized indication.
- » UPS battery back-up systems (sold separately) available for loss of power situations.
- » Available with stainless steel bottom plates for abrasive applications



Rated Lift* (lbs)	Watts	Dia. (in)	Height (in)	Weight (lbs)	Model No.
600	92	5-1/8	11-1/4	22	CER05
1200	135	6-3/4	11-1/4	41	CER07
2400	208	9	11-3/4	90	CER09
4000	420	12	13-5/8	140	CER12
7250	495	16	19-1/2	340	CER16
10500	1050	20	15	575	CER20

*Performance ratings on AISI 1020 steel.
Power required at 115/1/60 supply (watts)

CE ELECTROMAGNETS



The CE series magnets are circular electric lifting magnets that are specially designed for in-plant or outdoor handling of steel plate, bar stock, castings, forgings or machined components in all types of industrial plants, steel warehouses, shipyards and fabricating shops.

These magnets can be used individually or in multiples with different types of suspension systems. We engineer and supply the complete system including power supply, controls and battery back-up.

BENEFITS:

- » High strength steel bail
- » Low-carbon steel body for maximum magnetic performance
- » Heavy-duty, fully moisture-protected coils; 50% duty cycle
- » Coiled cord and twist lock adapter for quick connection to DC power source. (magnet controller required)
- » Mating twist lock receptacle provided for your installation convenience

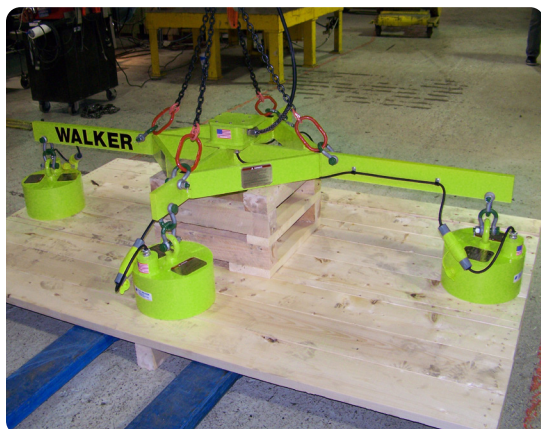

Rated Lift* (lbs)	Watts	Dia. (in)	Heights (in)	Mag. Height	Weight (lbs)	Model No.
600	62	5-1/8	7	4	13	CE05
1,200	86	7	8	5	40	CE07
2,400	148	9	8-1/2	5-1/2	80	CE09
4,000	340	12	8-3/4	6	138	CE12
7,250	654	16	16-1/4	7-3/4	295	CE16
10,500	1050	20	17-3/8	8-7/8	530	CE20

*Performance ratings on AISI 1020 steel.
Power required at 115/1/60 supply (watts)

Beams, controls, and engineering services available for turn-key systems & solutions.

SHEET LIFT SYSTEMS

MAGNETIC SHEET LIFT SYSTEMS



The Magnetic Sheet Lifter de-stacks steel sheets from pallets, racks and more. The unique design of this permanent magnetic lifting system allows one person to safely and effectively move and load sheets onto cutting tables, shear beds and other fabrication equipment. The Magnetic Sheet Lifter features a series of adjustable position permanent magnet lifting heads to lift a wide variety of sheet lengths and widths. Push button controls activate the air cylinders located on the magnetic heads. Once activated, the cylinders lift the magnets up into a housing and release the sheet in its desired location.

APPLICATIONS:

- » Stacking and destacking sheet steel
- » Loading shears, punch presses, press brakes and burn tables
- » Moving sheets/plates from pallets or racks to work stations

BENEFITS:

- » Allows one person to safely move sheet steel
- » Reliability of a permanent magnetic lift with the On/Off capabilities similar to an electromagnet
- » Fail-safe design (No battery backup required)
- » Adjustable magnet positions lift a wide variety of sheet lengths and widths.
- » Operates without the heat build up of electromagnets
- » Won't drop load due to power outages or system air loss
- » Only requires shop air for operation

FEATURES & SPECIFICATIONS:

- » Transporter® Technology Magnets
- » Structural tube framework
- » Durable, welded construction
- » Pneumatic release buttons on handles
- » Adjustable magnet head assembly locations
- » Pneumatic control valve provided
- » 1/2 NPT inlet fittings
- » Filter regulator with pressure gauge

OPTIONS:

- » Adjustable magnet positions are available to accommodate a wide variety of sheet lengths and widths
- » Low profile designs
- » Custom controls and hoist integrations
- » Custom safety equipment integrations

For more information on this product, contact us by phone, email or visit our website to request a Sheet Lifter Tech Sheet.

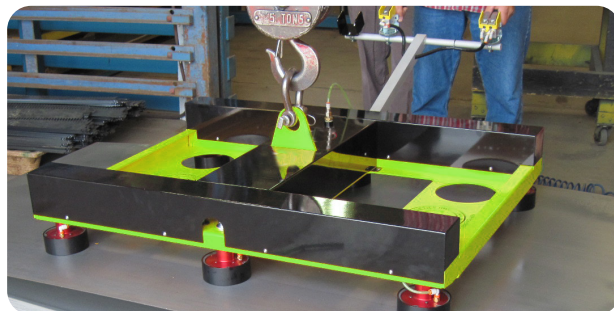
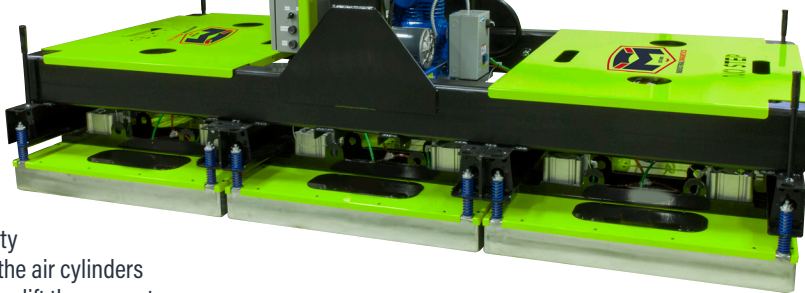

SHEET & SMALL PLATE LIFT SYSTEMS



FEATURES & SPECIFICATIONS:

- » Rare Earth Lift Magnets
- » Durable, welded construction
- » Spring-mounted for load compliance
- » Four-legged bridle
- » Structural framework

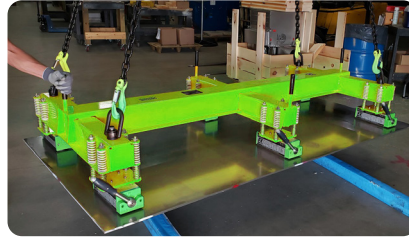

AIR ACTUATED - PERMANENT MAGNETIC SHEET LIFTER SYSTEMS



The Magnetic Sheet Lifter de-stacks steel sheets from pallets, racks and more. The unique design of this permanent magnetic lifting system allows one person to safely and effectively move and load sheets onto cutting tables, shear beds and other fabrication equipment.



The Magnetic Sheet Lifter features a series of permanent magnetic lifting heads to lift a wide variety of sheet lengths and widths. On-board or remote controls are provided to control pneumatic cylinders that are located on the magnetic heads. Once activated, the cylinders move the magnets in a housing and grip or release the sheet from or to its desired location.

FEATURES & SPECIFICATIONS:

- » Rare Earth Transporter® Magnets
- » Structural framework
- » Durable, welded construction
- » Pneumatic control valve(s) provided
- » Filter regulator with pressure gauge
- » Double acting compact cylinders

OPTIONS:

- » Custom handle and release mechanism configurations for specific applications
- » Special designs for customer specified sheet sizes or blanks
- » Magnet configuration for destacking
- » Load sensor for fail/safe release operation
- » Mounting plates to match robot EOAT



CUTTING TABLE LOADING/CLEARING

CUTTING TABLES



IMI's Automation Group and Walker Brand cutting table systems allow you to load and unload cut parts quickly and efficiently. Quick parts removal eliminates idle machine time.

- » Total or selective coverage
- » Efficient loading of plates, and unloading pieces and skeleton for burning operations
- » Quick parts removal eliminates idle machine time
- » Engineered for safe handling based on your specific plate/sheet size range specifications

Cutting table magnet systems are the easiest, fastest and most economical way to load plate onto a cutting table and then after cutting, to unload cut parts and the skeleton, in one step.

USED IN:

- » Flame cutting
- » Plasma cutting
- » Waterjet cutting
- » Laser cutting

BENEFITS:

- » No need to use grabs and chains
- » Efficient loading of plates
- » Efficient unloading of individual pieces and skeletons
- » Total or selective coverage
- » Quick parts removal eliminates idle machine time

AIR-ACTUATED PLATE LIFTER FOR CLEARING A CUTTING TABLE IN ONE PASS

AIR ACTUATED FEATURES & SPECIFICATIONS:

- » Rare Earth Transporter® Magnets
- » Structural framework
- » On-Board compressor
- » Pneumatic control valve(s) provided
- » Integration with hoist radio control
- » Double acting compact cylinders



TOTAL-COVERAGE SERIES MAGNETS



The new Walker Total-Coverage Series Magnets are designed to meet the special material handling needs required in precision flame, plasma and laser cutting table operations. The TC-Series Magnet will load plates up to 1.75" thick and after burning, unload cut parts and skeletons in a single lift. After unloading, it is possible to separate the skeleton from the cut parts.

Walker TC-Series Magnets eliminate time consuming handling of grabs and chains when you load and unload your burning table. Unlike mechanical methods, magnetic handling allows you to clear cut parts, unload skeletons and reload with new plates quickly, efficiently, and safely. This eliminates costly idle machine time, which translates into increased production.

The TC-Series is available in many standard and custom sizes.

Example: 4 ft. x 8 ft. to 8 ft. x 30 ft.

USED IN:

- » Special material handling needs required in precision flame, plasma, and laser cutting table operations.
- » Loading plate and then after cutting, unload cut parts and skeleton in one step.
- » Parts can also be separated from the skeleton to improve the sorting process.



WALKER HEAVY PLATE HANDLING & LIFTING



RL SERIES

Rectangular RL Series Magnets are designed to lift plates, slabs and billets of all sizes. Found in shipyards, metal working plants and service centers moving large plates to and from cutting tables, fabricating areas, welding departments and receiving and shipping areas. RLs can be used individually or in multiples with different types of suspension systems. IMI engineers can supply the complete system including spreader beam, powersupply, controllers, remote systems, special safety features and battery back-up systems.

APPLICATIONS:

- » Single Plate Lifting (destacking)
- » Multiple Plate Lifting
- » Hot Plate Lifting
- » Various Suspension Options
 - » Standard Beams, Telescopic Beams, Tilting Systems

OPTIONS:

- » Voltages: 115 or 230 VDC
- » Copper wound coils and Class "H" Insulation
- » Fully welded heavy duty magnet case
- » 50% Duty Cycle - Standard
- » 75% Duty Cycle - Optional
- » 100% Duty Cycle - Optional
- » Waterproof outlet box & lead cables
- » Flux Enhancement Pole Configurations
- » Wireless or wired controls



MAGNET HEAD SPECIFICATIONS									
Width (in.)	Length (in.)	Rated Lift Capacity (lbs)*	Power Consumption (WATTS)	Weight (lbs.)	Width (in.)	Length (in.)	Rated Lift Capacity (lbs)*	Power Consumption (WATTS)	Weight (lbs.)
8	16	0 - 3,500	400	150	16	32	0 - 14,000	1,300	800
	24	0 - 5,000	550	225		48	0 - 21,000	2,000	1,400
	32	0 - 7,000	725	300		64	0 - 28,000	2,600	1,800
	40	0 - 8,750	950	350		80	0 - 35,000	3,300	2,200
	48	0 - 10,000	1,000	400		20	40	0 - 21,000	2,250
12	24	0 - 8,000	700	325	60		0 - 31,500	3,200	2,200
	36	0 - 12,000	1,150	425	66		0 - 34,500	3,500	2,400
	48	0 - 16,000	1,250	600	80		0 - 42,000	4,500	2,850
	60	0 - 20,000	1,750	800	100		0 - 52,500	5,500	3,250
	72	0 - 23,500	2,300	1,000	26	48	0 - 39,000	3,100	2,400
	84	0 - 27,000	2,500	1,200		60	0 - 49,500	3,800	2,900

LIFTS FOR TUBES, STRUCTURAL PROFILES & BUNDLES

BUNDLE MAGNETS



Walker Bundle Lifting Magnets are used for a wide range of applications in all areas of the steel industry. They are frequently used in the production and handling of angles, channels, flats, I-beams, pilings, rebar, rounds and tubing.

OPTIONS:

- » Steel Mills
- » Metal Working
- » Service Centers
- » Warehouses
- » Shipping and Receiving
- » Fabricating Areas
- » Shipyards

Benefits:

- » Handle bundles quicker
- » Reduce dunnage cost
- » Reduce manpower
- » Increase storage capacity
- » Safer working environment
- » Can be used with fixed beams, rotating beams and expandable beams



POPULAR BUNDLE MAGNETS

BI-POLAR SERIES			GRABBER SERIES		
SIZE	AMPS @ 230 VDC	WT (lbs.)	SIZE (in.)	AMPS @ 230 VDC	WT (lbs.)
13x33	9	1,350	24x36	15	2,750
16 x 30	15	2,000	24 x 42	18	3,200
18 x 30	16	2,250	24 x 48	20	3,650
18 x 45	24	3,350	24 x 60	27	4,750

Deep Field Designs
Copper Wound Coils
Class H Insulation
Duty Cycles 50%, 75% or 100%
Hot Work Designs Available
Customized Pole Shoes to Maximize Magnetic Efficiency

LIFTS FOR TUBES, STRUCTURAL PROFILES & BUNDLES



TUBES

Lift Magnets include a wide range of Permanent, Battery Powered and Electro Magnets. These magnets handle a variety of plates, shapes and rounds.

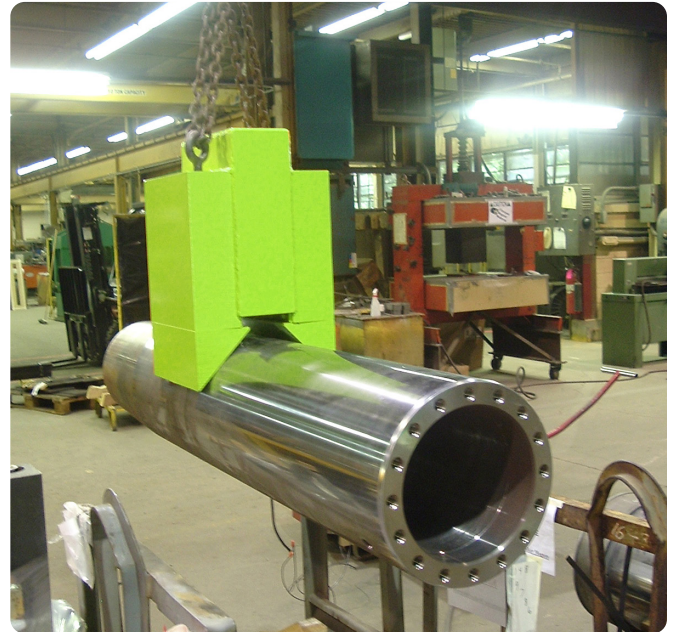

BUNDLES, SHAPES AND STRUCTURAL PROFILES

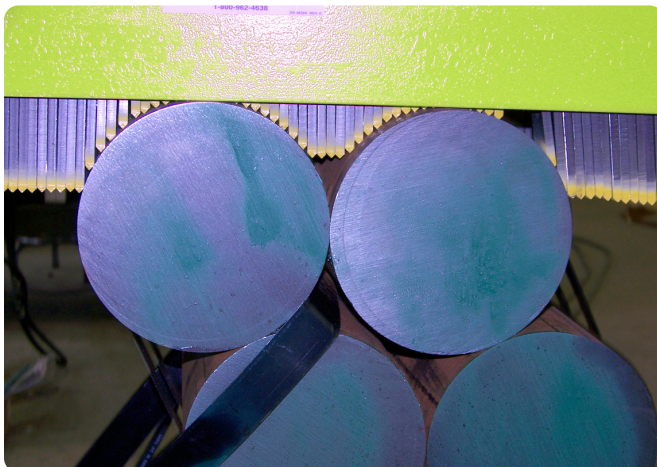
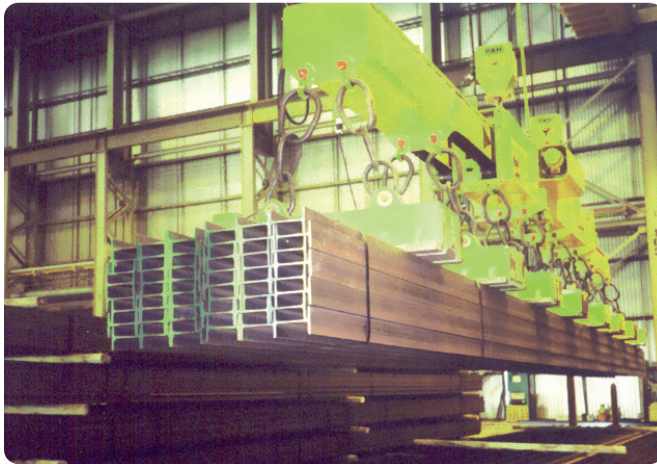

LIFTS FOR HOT PLATES & BILLETS

HOT PLATES



These magnets are designed to move hot steel directly from the cooling bed with no downtime. Time spent waiting for hot steel to cool down is wasted time. So is time spent handling steel with mechanical methods. With Heatmaster® Steel Mill Magnets, there's no wasted time. Hot steel can be moved quickly and easily, from the moment it leaves the casting bed.

Walker Heatmaster® Magnets utilize state-of-the-art materials and design features. During our years of experience in designing and building steel mill magnets, we have perfected several methods of coping with heat. For handling hot steel at up to 260°C (500°F), Heatmaster® Magnets have a special double bottom with an air space between the inner and outer bottom plates. The coil is isolated from the high temperatures by an air space, so hotter materials can be handled for longer periods of time without damage to the coil or the insulation system.

When the need to handle higher temperature material increases, IMI adds additional features based on a computerized thermal analysis. This thermal analysis has given our magnet design engineers the ability to vary the parameters and elements which effect the magnet's operating temperature.

Walker incorporates other special features into Heatmaster® Magnets, including 100% duty cycle operation, cooling fins, and proprietary insulation materials. Heatmaster® Magnets built with these unique design features run "cool" in extreme conditions.

BENEFITS:

- » Different models for different temperature ranges
- » No external cooling required
- » No hassles due to fans, radiators or waterlines
- » 75% and 100% Duty cycle operation
- » Welded watertight design
- » Special proprietary insulation utilized for layer-to-layer, turn-to-turn, coil-to-case insulation
- » Alloy steel lift chains or solid bails, as required
- » Heavy manganese steel bottom plate
- » Heavy-duty fabricated available





WALKER HEAVY LIFTING HEATMASTER SERIES

MOVE HOT STEEL DIRECTLY FROM THE COOLING BED WITH NO DOWNTIME. Different Models For Different Temperature Ranges No External Cooling Required, No Maintenance Hassles due to Fans, Radiators or Waterlines.

- » 75% and 100% duty cycle operation
- » Welded watertight design
- » Special proprietary insulation utilized for layer-to-layer, turn-to-turn, coil-to-case insulation
- » Alloy steel lift chain or solid bails as required
- » Heavy manganese steel bottom plate
- » Heavy-duty fabricated and construction

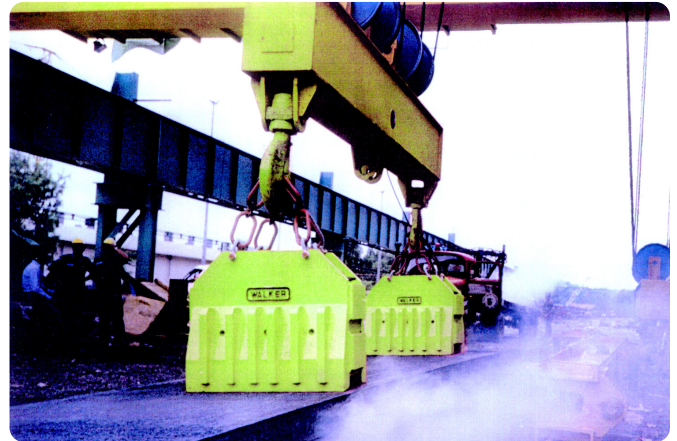

ELECTRO PERM MAGNETS



Walker Magnetics has been designing and manufacturing electropermanent devices since 1960. These magnets utilize permanent magnet material surrounded by an electrically powered coil. DC current is applied to the coil in order to magnetize and demagnetize the magnetic material. Once this current activates the magnet material, it becomes magnetic indefinitely with no loss of strength over time. In other words, electrical current can be completely removed with no reduction in the magnetic force available.

FEATURES:

- » Cold Operation
- » Cycle Time
- » Safer Holding



BI-POLAR SERIES LIFTING MAGNETS

Handling of bundles of pipe, tubing, rebar, bar stock, plate, structural shapes, castings, forgings, and coiled strips.



Bi-polar magnets lift directly from the center of the load, so no aisle room is required to sling or maneuver a hook into the eye. Loads can be stacked as high as the crane allows.

Walker Magnetics offer 2 styles of bi-polar magnets depending on the technical needs.



LIFTS FOR COILS & LARGE BILLETS

BILLETS



Walker provides heavy steel mill duty magnets for handling hot or cold, billets, slabs, and rail. Walker billet and rail handling magnets are available in a wide range of sizes to accommodate your application. Because the majority of our magnets are welded, fabricated designs, we can customize the size as well as many optional features.

There are two basic magnetic circuits that we use in the designing and building of these magnets: the well recognized "grabber" three-pole design and the "bi-polar" two-pole design.

The Grabber Magnet was developed to help mills that were having difficulty lifting full layers of billets due to the air gaps between the magnet's face and the billets. These gaps are not unusual in normal steel mill production and it was time-consuming to make return trips to retrieve bent billets that were not lifted the first time. Walker engineers designed billet magnets with very high penetrating power that are able to "snap-up" the bent billets, making full, dynamic lifts.

The Grabber Magnet is most efficient for ambient temperature billet handling, but can easily be supplied with Walker's Heatmaster features for handling billets at elevated temperatures.

The bi-polar design has all of the high powered penetrating ability of the Grabber style lifting magnets but has proven to have superior heat resistant capabilities due to the location and attitude of the coil. These magnets are generally taller and heavier than the equivalent capacity Grabber style magnet, but these features contribute to the advantages that these magnets have for higher temperature steel handling.



COILS



Walker Lift Magnets are the easiest, fastest and most economical way to lift and handle steel coils. Since the magnet is in contact and holding only the top of the coil, potential coil damage is virtually eliminated. We have the ability to lift coils in the vertical or horizontal orientation.

USED IN:

- » Annealing shops
- » Metal Working
- » Service Centers
- » Warehouses
- » Shipping and Receiving
- » Fabricating Areas

BENEFITS:

- » No damage to coils while handling
- » Only one operator is needed - freeing up man power
- » Less storage area is needed - reducing floor space
- » Electromagnet and Electro-Permanent magnets are available

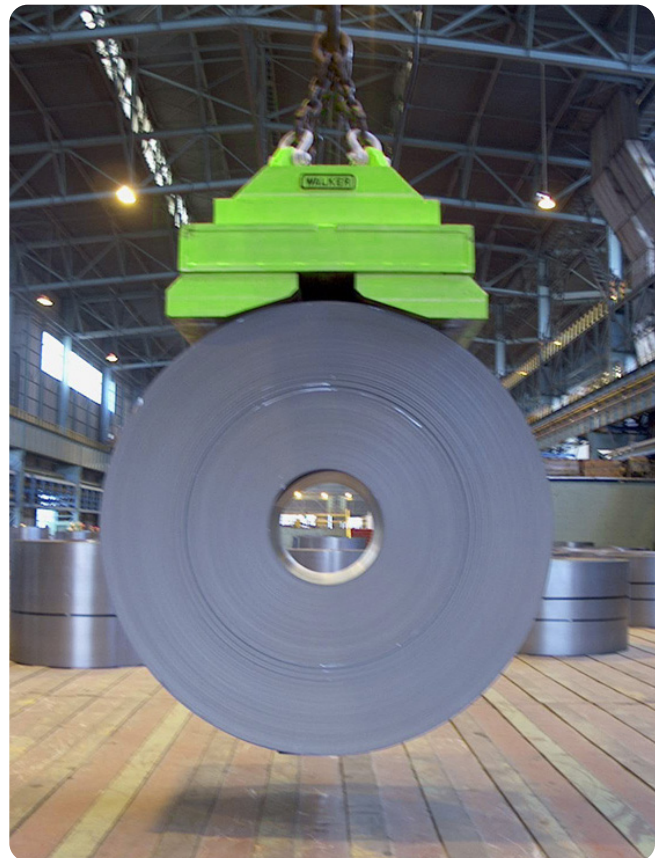
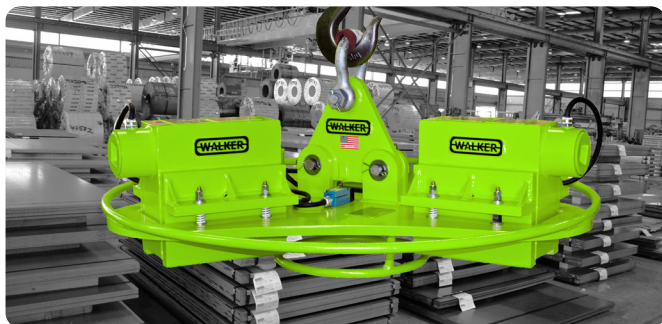

SCRAP LIFTING MAGNETS

The Scrapmaster III Series has been designed specifically to fit the needs of scrap processing operations. From a utilitarian 40" to a giant 100" magnet diameters and weights were selected to maximize the lifting capabilities of standard scrap handling cranes. The high lift-to-weight ratio of these magnets allows the movement of more and heavier scrap.

The Scrapmaster III Series magnet has a rugged ribbed case, heavy-duty manganese bottom plate, welded watertight construction and tough alloy steel chains for maximum durability. All elements are designed for top operating efficiency, with deadweight engineered out.

SPECIFICATIONS								LIFTING CAPACITY (lbs.)		
Model	Dia.	Approx. wt. (lbs.)	D.C. Voltage	Amps (cold)	Generator (KW)	Controller (amps)	Minimum Cable Size	#1 Heavy Melting	#2 Heavy Melting	Steel Turnings
40D	40"	1,800	230	35	10	50	#8	0 - 900	0 - 600	0 - 375
45DSH	45"	2,700	230	43	10	50	#8	0 - 1,500	0 - 1,030	0 - 480
48D	48"	2,900	230	58.5	15	75	#8	0 - 1,750	0 - 1,160	0 - 600
54DSH	54"	4,150	230	63	15	75	#6	0 - 2,560	0 - 1,660	0 - 730
57D	57"	4,400	230	75	20	75	#6	0 - 2,700	0 - 1,800	0 - 850
63DSH	63"	6,180	230	82	20	100	#4	0 - 3,970	0 - 2,580	0 - 1,230
66D	66"	6,400	230	91	30	100	#4	0 - 4,100	0 - 2,750	0 - 1,350
69DSH	69"	8,000	230	99	30	100	#4	0 - 4,520	0 - 3,000	0 - 1,360
72D	72"	8,300	230	113	30	125	#4	0 - 4,700	0 - 3,150	0 - 1,500
78D	78"	10,300	230	126	30	150	#2	0 - 5,700	0 - 3,800	0 - 2,000
87D	87"	12,500	230	168.5	40	175	#2	0 - 6,825	0 - 4,550	0 - 2,600
92D	92"	15,400	140	218	40	220	#2	0 - 8,500	0 - 5,660	0 - 3,000

SCRAPMASTER D/DSH MAGNETS



Lifting capacities are based on optimum conditions. Variables in the materials or magnetic system can affect performance. Material description based on specifications for iron and steel scrap published by the Institute of Scrap Recycling Industries.

- » 75% duty cycle standard
- » Steel Mill Operations
- » Foundry Operations
- » Scrap Yard Processing
- » Waste Processing
- » Crop Pit Applications
- » Under Water Applications
- » Burn Table Applications
- » Manufacturing Scrap Waste Handling
- » Fabrication Scrap Waste Handling
- » Demolition Clean Up
- » Hot Works Available



RLSD SCRAP MAGNETS

RLSD SERIES STEEL MILL MAGNETS



Rectangular shaped scrap handling magnets are the newest development from Walker Magnetics. Designed to lift large volumes of scrap in and out of confined areas, these powerful magnets are becoming the standard in melt shops around the world. Extra heavy-duty construction with unique Multiple Bumper Perimeter Plates and resilient manganese steel bottom plates make this the toughest scrap magnet ever! Available in a wide variety of sizes, these tough welded RLSD's operate cool 24 hours per day, 7 days per week.

- » Scrap Yard Processing
- » Rail Car loading/unloading
- » Barge loading/unloading
- » All welded heavy duty construction
- » Manganese steel bottom plate
- » 75% duty cycle
- » Cooling operating
- » Class H insulation
- » Powerful deep field design
- » Quick disconnect lead assembly
- » Precision wound Aluminum Coil
- » Precision wound Copper Optional

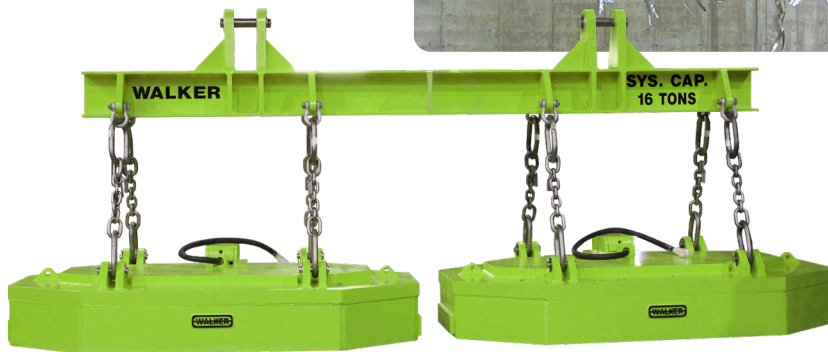

MILLMASTER "D" SERIES



EXTRA HEAVY DUTY, DEEP-FIELD AND EXTRA DEEP-FIELD MODELS

Millmaster® "D" is a special series of heavy duty lifting magnets designed for steel mill use. For added impact resistance, a rugged ribbed case is cast from a special high-strength alloy steel that combines high strength and magnetic permeability. The special bottom plate is wear resistant manganese steel with an extra-heavy cross section. The case has welded watertight construction and utilizes tough alloy steel chains. Millmaster®D is available in standard, deepfield, and extra deep field strengths. Models are offered with Aluminum Coils or Copper Coils. All elements are specially engineered and designed for ultimate lifting performance with mechanical strength. The result is a lifting magnet that sets the standards for performance, endurance, and reliability. From heavy duty chain through high temperature insulation to specially-designed-and built winding hubs, Millmaster®D technology offers every insurance against costly downtime.

- » 75% Duty Cycle
- » Maximum slag/slab/dropball capacity
- » Extra rugged cast steel case
- » Larger pole shoes
- » Triple sealed terminal box
- » Heavy manganese steel bottom plate
- » Alloy steel chains for greater life and durability



LIFT MAGNET SYSTEM CONTROLS

SSC CONTROL MASTER



The Solid State Controller (SSC) is compatible with all electromagnets. It includes the option to have infinitely variable power control. These controllers have fanning/dribble options and are radio control compatible. Reduced initial power (RIP) safety feature included on all standard models. They are lighter than traditional magnet controls. Outdoor enclosures are available upon request. Multiple magnet selection options are also available upon request along with multi-drive options for independent operation.

- » Enhanced magnet performance
- » Infinitely variable power control available
- » Reduced maintenance
- » Solid state digital design
- » AC line circuit breaker disconnect
- » Fanning/dribble
- » Radio control compatible
- » Reduced cycle time (faster lift/faster drop)
- » Compatible with all electro magnets
- » Smaller and lighter than traditional magnet controls
- » Magnet "ON" indicator light
- » AC noise suppression circuit
- » Runs cooler
- » Type 12 enclosure with forced air - standard
- » Type 3R, 4 and 4X enclosure available
- » Magnet temperature monitor alarm available
- » Multiple magnet selection available
- » Multiple drive option available
- » Reduced initial magnet power feature standard



BATTERY BACK-UP SYSTEM



Battery Back-Up Units are used to provide 20 minutes of emergency power to the magnets in the event of an interruption of power to the crane. The Battery Back-Up System is designed for use with the SSC Controlmaster Solid State Digital Power Converter/Magnet Controller and Traditional Walker PCCU Controller. This unit provides a highly regulated charging system that never requires adjustment in the field to provide maximum battery life with minimal maintenance. The charging system monitors both the charging voltage and the charging current. A PLC monitors the data and keeps the batteries at the correct float voltage regardless of line fluctuations. Outdoor enclosures are available upon request.

- » PLC based solid state controls for reduced maintenance and ease of troubleshooting
- » Continuous voltage monitoring
- » Continuous current monitoring
- » Door mounted: charging indicator light, charger fault light, magnet-on-batteries indicator light, horn silence push button, battery voltmeter, and battery ammeter
- » Diagnostic circuitry and feedback
- » Remote mounted 98dB alarm sounds to indicate magnet-on-batteries and fault conditions
- » Optional remotely mounted display section
- » Type 12 enclosure with louvers, Type 3R, 4, and 4X available
- » Door mounted battery disconnect switch



CUSTOM CONTROL OPTIONS

All controls can be customized for individual needs.

TRANSPORTERS® & END OF ARM TOOLING

TRANSPORTER® SWITCH SERIES (TPS)

Ideal for use where vacuum cups and grippers are typically used for lifting and moving steel sheets, blanks, stamped parts and complete assemblies.

APPLICATIONS & BENEFITS:

- » Automated press to press transfer systems & robotic "Pick & Place"
- » Manual and automated machine loading/unloading
- » Outlasts vacuum cups in most applications
- » Grasps odd shaped or perforated parts
- » Will not drop parts if system air-loss occurs
- » Reduces noise
- » Maximum operating temperature 140°F (60°C)
- » Destacks* without double-blanking when the appropriate magnet is selected for the application
- » Double Acting
- » Maintains magnetic state in event of air loss
- » Easy to retrofit on existing tooling
- » Sensors available to provide gripper state feedback
- » Instantaneous pick-up and release
- » Uses up to 95% less air than vacuum cups
- » Friction plate option: Non-marring face, lowers holding value, see chart.

OPTIONAL EQUIPMENT:

- » Apple core mount
- » Ball mount
- » 3/8" NPT mount
- » V-brackets to keep rounds or 90° degree shapes centered on the magnet. Made of UHMW to provide
- » Non-marring contact.

For more information on this product, contact us by phone, email or visit our website to request a TPS Tech Sheet.

Non-marring version



TRANSPORTER® MAGVAC (TPMV)

The Transporter® MagVac combines magnet technology with vacuum cups to create a next generation lifting tool.

BENEFITS:

- » Powerful magnetic gripper combined with a vacuum cup for powerful holding
- » Lift steel or perforated parts as well as aluminum and stainless steel
- » Perfect for robotic systems, press transfer systems and all sheet metal applications
- » Vacuum pads can be removed for single use as a standard lift magnet on ferrous parts
- » No more replacing vacuum cups every week
- » No dropping parts from loss of air (for ferrous parts), excess mill oil or weld slag
- » Maximum temperature of 176°F (80°C)
- » All suction cup pads are made from Thermoplastic Polyurethane/TPU



For more information on this product, contact us by phone, email or visit our website to request a Transporter Tech Sheet.

IXTUR® PNEUMATIC MAGNETS

IXTUR Pneumatic Magnets are ideal for use where vacuum cups and grippers are typically used for lifting and moving steel sheets, blanks, stamped parts and complete assemblies. Perfect for automated press to press transfer systems, robotic pick & place systems and machine loading/unloading.

BENEFITS:

- » Outlasts vacuum cups in most applications
- » Grasps odd shaped or perforated parts
- » Increases production and reduces shop air costs
- » Operates effectively in any orientation
- » Will not drop parts if system air-loss occurs
- » Maximum operating temperature 122°F (50°C)
- » Double-Acting ON/OFF - Air pressure required only to change state from off to on and on to off.

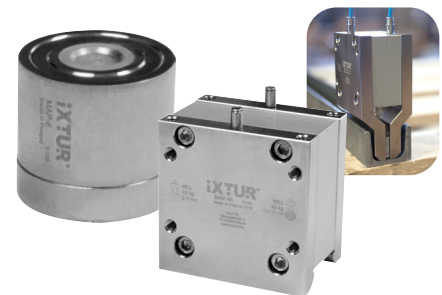

For more information on this product, contact us by phone, email or visit our website to request an IXTUR Tech Sheet.

TRANSPORTERS® & END OF ARM TOOLING



TRANSPORTER® LP LOW PROFILE (TPLP)

The Transporter® LP is designed to directly replace vacuum cups with minor tooling and valve adjustments. Powerful Rare Earth magnets positively hold the parts during transfer. An optional "low-skid" boot is available to increase grip on parts during transfer. A short burst of air pressure is applied to release parts. Perfect for automated press to press transfer systems, robotic pick & place systems and machine loading/unloading

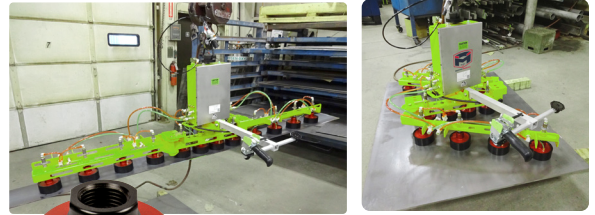

FEATURES:

- » Uses up to 95% less air than vacuum cups
- » Outlasts vacuum cups in most applications
- » Grasps odd shaped or perforated parts
- » Operates effectively in any orientation
- » Class "A" blank protection with optional boot
- » Destacking option prevents double-blanking
- » Rare Earth magnet positively holds parts - no dropping or shifting in the event of air loss
- » Threads onto a variety of typical 3/8 NPT vacuum cup tooling

Transporter LP Options

Double Acting (Option DA): Features seals & an extra air inlet that allow a short blast of air to engage or disengage the grip function. The double acting option is only available on the TPLP30 & TPLP50 magnets.

De-stacking (Option DS): This is required for applications de-stacking metal that is thinner than .064" (14 ga or less) with the TPLP30 model. The de-stack option is designed to de-stack sheets as thin as .030" (22 ga). The optional low-skid boot is required for certain applications.

For more information on this product, contact us by phone, email or visit our website to request TPLP Tech Sheet.

3/8 BSPP Fitting (Option BS): 3/8 British Standard Pipe Parallel Thread, available on TPLP30 models only.



TRANSPORTER® LP ACCESSORIES



We offer a large selection of TPLP accessory to handle your installation, operation and maintenance requirements such as various mounting options, manifolds and magnet face covers.

The Bulk Head Spring Mount is ideal for installation on end user specified mounting plates. For crash compliance, not load compliance. The Proximity switch mount is designed for the TPLP15 and TPLP30 and accepts a 12mm proximity switch.

The **Swivel Mount** or **Spring Compensator** can be added to new or existing Transporter TPLP30's for best part compliance. These lightweight, anodized, aluminum constructed mounts fit most TPLP30 magnets to accommodate material variances and uneven surfaces. Low center of rotation allows magnet to stay on target. Our newly styled upper housing was redesigned with a groove to accommodate these mounts. If your TPLP30 does not contain a mounting groove, a replacement upper housing can be purchased.

Low Skid Boots and Pads protect against marring of class "A" blanks while reducing the likelihood of part shifting and extending the life of the magnet by protecting the face from wear and. The boots cover the edge of the cup for complete blank protection while the pads cover the face of the cup for increased wear protection to extend the life of the magnet.

For more information on this product, contact us by phone, email or visit our website to request TPLP Tech Sheet.



Swivel and Spring Compensator mounting fixtures available for new and custom tooling installation.

LIFTING ACCESSORIES

WELD-ON PADEYES

Engineered and certified to meet all ASME BTH-1 categories and classes. Eliminate the need and time to engineer, fabricate, machine and certify lifting padeyes. By purchasing these one-of-a-kind padeyes, you can have them on the shelf ready to weld and speed up delivery, testing and approval of your projects.

FEATURES:

- » Hole is reamed to fit shackle pin/bolt ± 0.01"
- » Weldable A36 Carbon Steel
- » Weld Spec and Weld Line on Padeye
- » Date Coded
- » Engineered and Certified

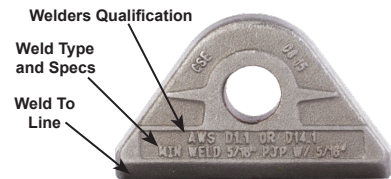
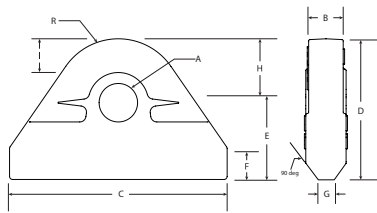

WLL (Tons)	Shackle Size (in)	A (in)	B (in)	C (in)	D (in)	E (in)	F (in)	G (in)	H (in)	I (in)	R (in)	Weight (lbs)	Minimum Weld	Carbon Steel Model No.
1/2	1/4	21/64	11/32	2-7/64	1-3/8	3/4	5/16	N/A	5/8	7/16	5/8	0.20	0.188"	PE0050
1	3/8	15/32	9/16	2-7/16	1-5/8	7/8	3/8	N/A	3/4	1/2	3/4	0.40	1/4"	PE0100
1-1/2	7/16	17/32	5/8	2-3/4	1-9/16	7/8	1/4	7/32	11/16	13/32	11/16	0.40	3/16 PJP with 3/16" Fillet	PE0150
2	1/2	43/64	11/16	3-1/4	2-1/8	1-1/8	7/16	5/32	1	21/32	1	0.80	1/4 PJP with 1/4" Fillet	PE0200
4-3/4	3/4	15/16	1-1/8	4-7/16	2-5/8	1-7/16	1/2	15/32	1-1/4	25/32	1-1/4	2.20	5/16 PJP with 5/16" Fillet	PE0475
6-1/2	7/8	1-1/16	1-5/16	5-3/16	2-15/16	1-5/8	1/2	3/8	1-5/16	25/32	1-5/16	3.05	7/16 PJP with 7/16" Fillet	PE0650

WLL = Working Load Limit

Request Padeyes Tech Sheet

COMPACT LID REMOVER

Magnetic lid remover offers a lightweight and compact, one-piece design that is easy to use, store and transport. Harnessing the forces of magnetism and leverage, users can remove and replace manhole lids up to 450 lbs. .

To operate, remove the protective guard from the magnet, and carefully place the unit on the edge of the manhole cover. Make sure the leverage bar is on a solid surface (road). Push down on the handle to raise the lid from the manhole and pull backwards to clear the lid from the hole. The magnet is freed from the lid by moving the handle over the magnets in the opposite direction.

FEATURES:

- » Powerful Rare Earth Magnets
- » Durable Stainless/Aluminum Construction with Rubber Grip T-Handle
- » Magnet storage guard when not in use

Description	Wt. (lbs)	Model No.
One-Piece, T-Handle, Two Magnets, 36" Tall, 12" Wide	25	MCL450



ON/OFF MAGNETIC UTILITY LIFTER

Stop bending over to lift and remove cast iron utility and valve box covers! Also lifts pipes and other steel items.

Reduce finger and toe injuries with this lightweight deep reach switchable permanent magnetic lifter. The magnetic field penetrates textured surfaces of lids and allows the operator to ergonomically lift the casting out of the way.

This Magnetic Utility Lifter has a locking On/Off handle for safety and makes removing covers quick and easy.

Lift - lbs (kg)	Height (in)	Width (in)	Length (in)	Weight (lbs)	Model No.
50.0 (22.68)	28-1/2	5-1/2	3-1/2	7.65	MCLVB01
75.0 (34.02)	28-1/2	7	5	14.25	MCLVB02



TUBE LIFTERS & PALLETIZERS/DEPALLETIZERS

MAGNETIC TUBE LIFT SYSTEMS



The Magnetic Tube Lifter transfers steel tubes from pallets, racks, work stations and more. In manual applications, this unique design allows one person to safely and effectively move and load steel tubing. Tube lifters can also be designed for automated applications to transfer tubes within a system. The Magnetic Tube Lifter features specially designed permanent magnetic lifting heads to lift a variety of tube shapes, diameters and wall thicknesses. To release tubes from the powerful magnetic heads, air cylinders are activated lifting the magnets up inside of the housing, allowing the tubes to be set down.

APPLICATIONS:

- » Loading/Unloading saws, cutting stations, welding cells and pallets
- » Transferring tubes for hydroforming
- » Moving single or multiple tubes between work stations

BENEFITS:

- » Works on round, square & custom shaped tubing
- » Reliability of a permanent magnetic lift with On/Off capabilities
- » Fail-safe design (No battery backup required)
- » Will not drop parts during a power or air loss



For more information on this product, contact us by phone, email or visit our website to request a Tube Lift Tech Sheet.

TRANSPORTER® - CYLINDER ACTUATED (TPCA)



Transporter® Magnets are ideal for use where vacuum cups and grippers are typically used for lifting and moving steel sheets, blanks, stamped parts and complete assemblies.

APPLICATIONS & BENEFITS:

- » Automated press to press transfer systems
- » Robotic "Pick & Place"
- » Manual and automated machine loading/unloading
- » Outlasts vacuum cups in most applications
- » Grasps odd shaped or perforated parts
- » Increases production and reduces shop air costs
- » Designed for long, maintenance-free operation
- » Operates effectively in any orientation
- » Will not drop parts if system air-loss occurs
- » Destacking (requires proper magnet selection)

OPTIONS:

- » Solenoid control valves
- » Custom designed magnet housings
- » Alternate magnetic circuits for specific lifting requirements
- » Magnet mounted control valves
- » Magnets designed into ergonomic lifting systems

FEATURES:

- » Will not drop parts during a power or air loss
- » Instantaneous pickup and release
- » Permanent magnet requires no electricity



Cylinder Actuated Transporter® Magnets (TPCA)

The patented Transporter® utilizes a Rare Earth, Permanent Magnet to pick and place metal parts in automated transfer and manually operated material handling applications. Offering more options for pick-up points on stamped, forged and formed parts or complete parts assemblies. Offers increased material handling safety and a significant reduction over vacuum cups in shop air costs.

Ideal for steel lifting applications in the Automotive, Appliance and Office Furniture industries and available in many standard and custom configurations to best suit the needs of your application.

For more information on this product, contact us by phone, email or visit our website to request a Transporter Tech Sheet.

MAGNETIC PALLETIZERS AND DEPALLETIZERS



Safely and efficiently transfer steel items to be palletized or depalletized

Custom designed Palletizers/Depalletizers provide a safe and efficient method of transferring of steel items without the need for additional holding devices.

Typically equipped with pneumatic releases, Palletizers/Depalletizers are ideal for automated transfer of full or empty food and beverage cans, brake drums and rotors, jars with steel lids, paint cans, composite cans, batteries, oil filters and more!

BENEFITS:

- » Reliability of a permanent magnet with the On/Off capabilities of an electromagnet
- » Increased production for palletizing or depalletizing steel items
- » Reduced repetitive labor

For more information on this product, contact us by phone, email or visit our website to request Palletizer Tech Sheet.

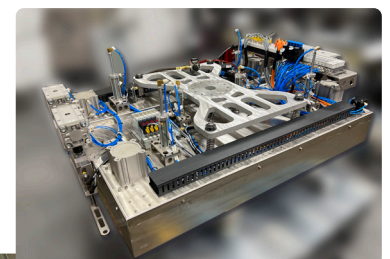
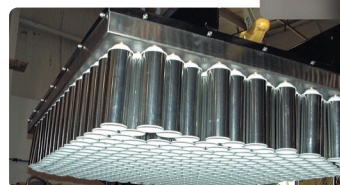

Shown with suction cups for transferring slip sheets

CUSTOM MAGNETIC LIFTING SPECIALISTS



Our factory experts will develop a unique magnetic lifting device if a standard magnetic lift doesn't work for your application. We will be there every step of the way from field sales support to design, manufacturing and final testing.

For more information on our custom lifting products, please contact us today at 888.582.0823 or go online to www.magnetics.com

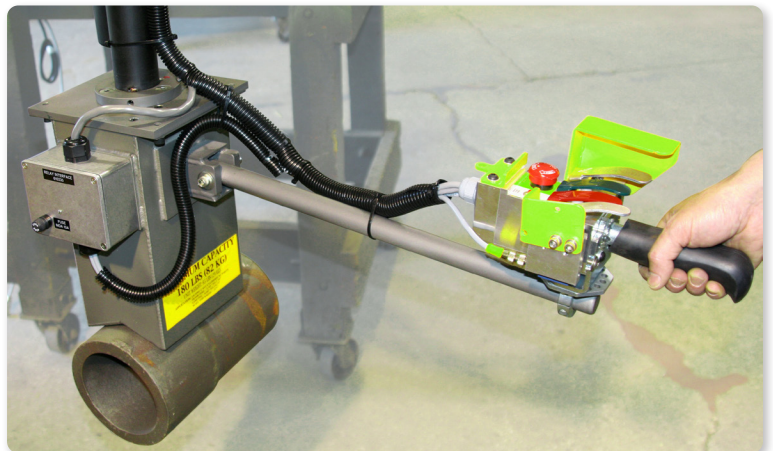
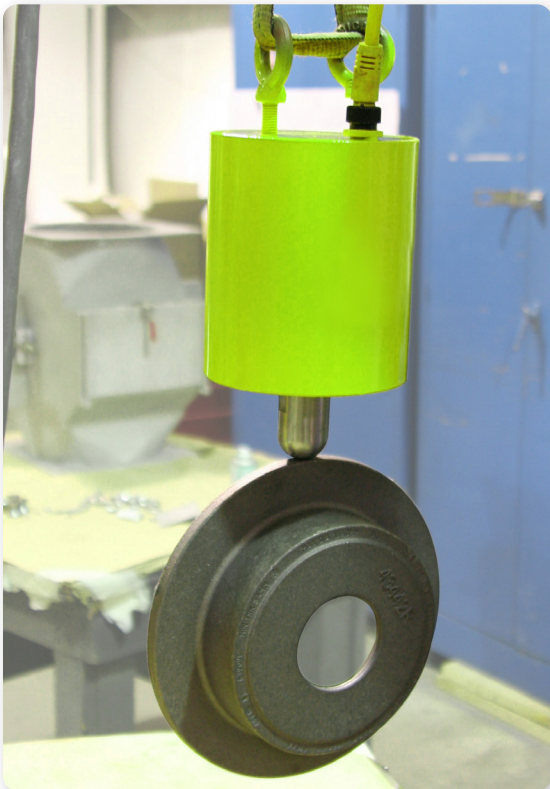
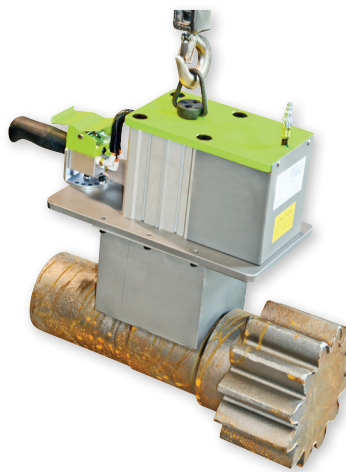

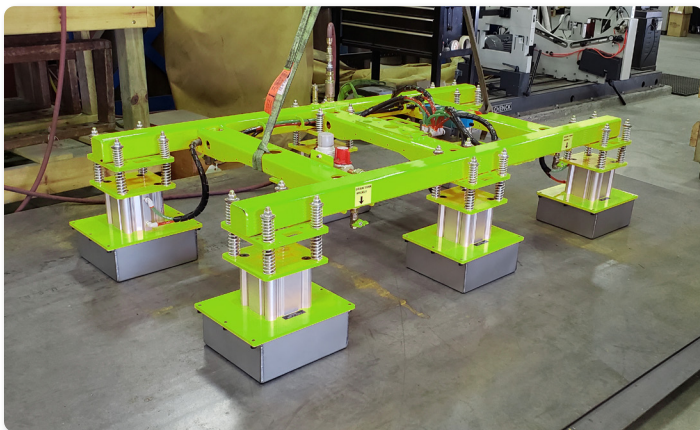
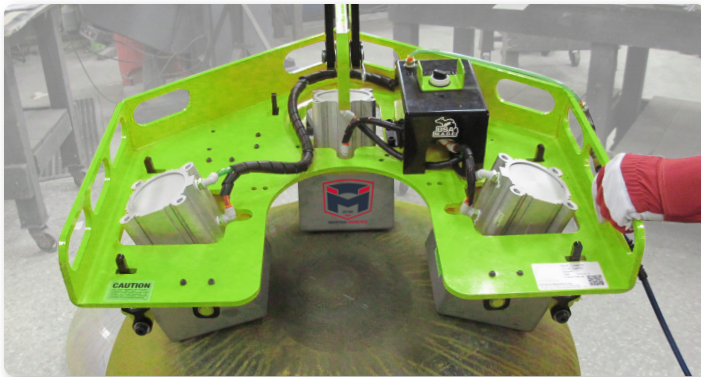
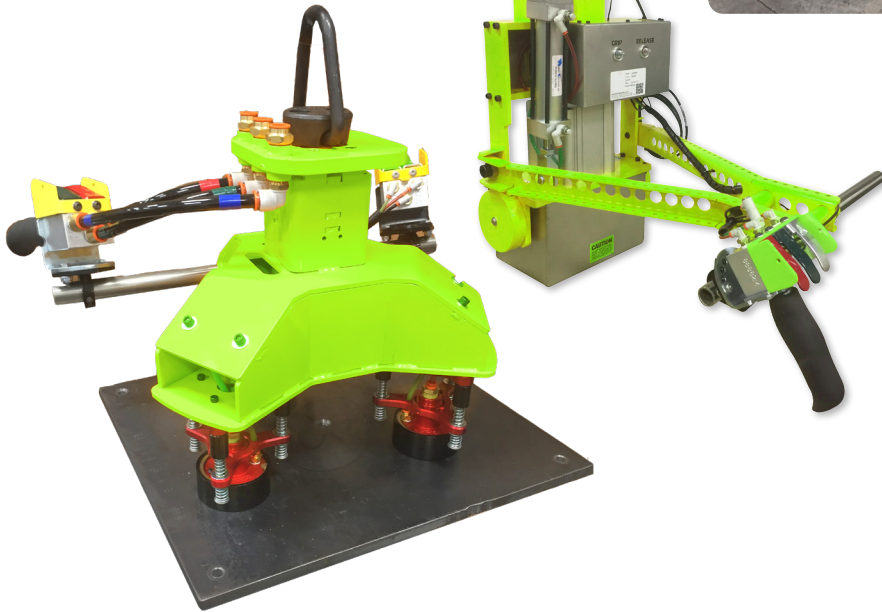
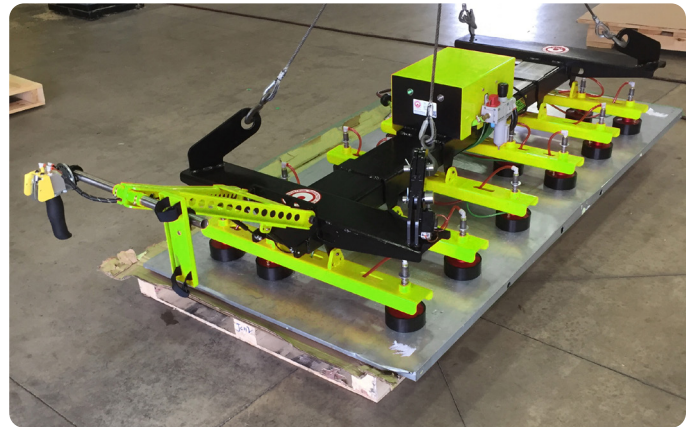

MANHOLE COVER LIFTS

MANHOLE COVER LIFT DOLLY SYSTEM, MANHOLE COVER LIFT SYSTEM



Easily move heavy manhole covers up to 400 lbs. without worrying about your fingers, toes and back. This cover lift system uses a unique adjustable four-position hook with a four-length retractable handle for terrific leverage, even in tight spots. The three angle positions (90°, 105° and 120°) let you adjust the system for any lifting situation. The safety latch hook makes grabbing the magnet or spreader bar a one-person job. Choose from steel or aluminum dollies. Dollies include your choice of heavy-duty 6", 10" or 12" diameter wheels. The dolly folds up and handle breaks down for easy storage. When fully extended, the handle length is 64"; when folded and collapsed down it is 41" long.

It doesn't matter if you are 5'6" or 6'5", the MCL Dolly can be adjusted to ergonomically accommodate any user.

- » Reduce lost time injuries caused by handling covers
- » Minimize stress & strain on your body—system does the heavy work for you
- » Retractable four-length handle gives maximum leverage from any angle
- » Ideal for survey crews, handle breaks down for easy storage & transportation
- » Makes moving covers fast, easy and a one-person operation

Several magnet and hook configurations are available for use with your dolly

Use each dolly with either a single magnet in the center of the manhole cover, or with two magnets and a spreader bar (magnets and spreader bar sold separately). When using two magnets on a spreader bar, the load is more balanced—ideal for large covers or heavily textured surfaces. The spreader bar has three location holes so you can place the magnets where you gain the best magnet-to-steel-ratio. A sample of common On/Off Locking Rare Earth magnet choices are listed in the table below. Contact us to for more information on other magnet options.

The optional cover lift Dolly Extension Hook lets you lift very large diameter manhole covers that might otherwise interfere with proper dolly operation. Use on covers up to 54" for 6" wheeled dollies, 50" for 10" wheeled dollies or 48" for 12" wheeled dollies.



MCL3W06VL0600

Manhole Cover Lift Spreader Bar Specifications

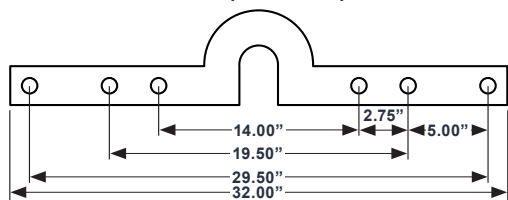

COVER SAMPLES AND RECOMMENDATIONS

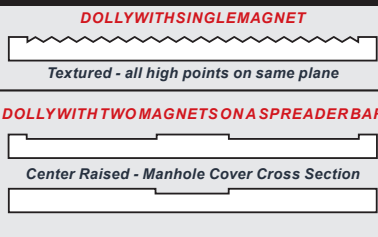

Low Center - Manhole Cover Cross Section

Manhole Cover up to 26" dia. - Magnet & Dolly Combo		
Model No.	Description	Weight (lbs)
MCL2W06PNL0800	Steel Dolly with 6" Wheels and PowerLift Magnet	46 + 21
MCL2W12PNL0800	Steel Dolly with 12" Wheels and PowerLift Magnet	52 + 21
MCL3W06AL0660	Aluminum Dolly with 6" Wheels and AdvantageLift Magnet	29 + 33
MCL3W12AL1200	Aluminum Dolly with 12" Wheels and AdvantageLift Magnet	34 + 46
30"-35" dia. Manhole Covers & Trench Grates - Magnet & Dolly Combo		
MCL2W06PNL1600	Steel Dolly with 6" Wheels and PowerLift Magnet	46 + 51
MCL2W12PNL1600	Steel Dolly with 12" Wheels and PowerLift Magnet	52 + 51
MCL3W06AL1200	Aluminum Dolly with 6" Wheels and AdvantageLift Magnet	29 + 46
MCL3W12AL1200	Aluminum Dolly with 12" Wheels and AdvantageLift Magnet	34 + 46
For 36" and greater dia. Manhole Covers or Grates, Vented Lids, Heavily Textured Surfaces a Dolly, plus a Spreader Bar with (2) magnets from menu below, i.e. MCL200W06 + MCL660X2		
Dollies Only		
MCL2000W06	Dolly, Steel, 6" Wheels	46
MCL2000W10	Dolly, Steel, 10" Wheels	52
MCL2000W12	Dolly, Steel, 12" All-Terrain Wheels	52
MCL3000W06	Dolly, Aluminum, 6" Wheels	29
MCL3000W10	Dolly, Aluminum, 10" Wheels	34
MCL3000W12	Dolly, Aluminum, 12" All-Terrain Wheels	34
Magnet Options		
MCL660X2	Spreader Bar with (2) PNL0800 Magnets	49
MCL600X2	Spreader Bar with (2) Premium VL0600 Magnets	47
PNL0800	Powerlift® Magnet only, 800 lbs Rating	21
PNL1600	Powerlift® Magnet only, 1600 lbs Rating	51
AL0660	The AdvantageLift™ On/Off Permanent Rare Earth Lift magnet	20
AL1200	The AdvantageLift™ On/Off Permanent Rare Earth Lift magnet	37
Accessories		
MCLWC18X16	Wheel Chocks 18" x 16"	17.5
MCLHOOKEXT	Dolly Hook Extension for Manhole Covers up to 48"	3



MANHOLE COVER LIFT PRODUCTS

HD MANHOLE COVER LIFT SYSTEM



The Heavy Duty (HD) manhole cover lift dolly and Magnet & Dolly Combination system take several key features of our regular manhole cover lift system and adds an extra telescoping handle, giving you more leverage when lifting manhole covers.

Description	Wt. (lbs)	Model No.
Steel dolly, 12" Wheels, Hook Extension, 3pc telescoping Handle	58	MCL2000W12HD
All the above plus a PNL1600 On/Off PowerLift® magnet	58 + 51	MCL2W12HDPNL16

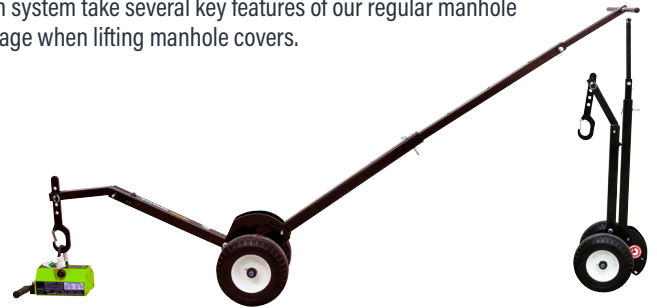

POWERARM™ - VEHICLE MOUNTED

The Manhole PowerArm™ makes lifting and replacing manhole covers the most ergonomic. Great for repetitive access like survey/cleaning crews. Electric Hoist: drive within 3 feet of the center of the lid and let the "Arm" adjust to your location. This "Arm" has a 3-foot, 180° swing radius that allows the positioning of the magnet to the center of the manhole cover. Manual Hoist: Use backup camera to get as close to center as possible. Both "Arms" have 400 lbs. lifting capacity, fit into a standard 2" square receiver hitch and are constructed of welded tubular steel. (Rare Earth Magnet sold separately). Use PowerArm™ to lower items such as camera tractors, large sewer nozzles, pipe plugs, etc.

ELECTRIC HOIST SPECIFICATIONS:

- » 55 AMP, 12 VDC with power-up & power-down control, removable
- » 16' remote control cord and a 20' galvanized cable with latch hook
- » Provided with a 2-Pole DC power connector, heavy-gauge 13' lead to connect hoist to vehicle battery (+) positive terminal and 6' long ground cable to connect to vehicle frame

MANUAL HOIST SPECIFICATIONS:

- » Worm Gear hoist that will hold load when handle is released
- » Polyester strap with Zinc-plated hook & safety latch
- » Remove hoist, insert sideways for tailgate access, storage, and travel



Winch Type	A (in)	B (in)	C (in)	Weight (lbs)	Model No.
Electric	56-3/8	17-13/16	7-1/4	87	MCLPAE2000
Manual	30-7/8	20-1/2	20-13/16	30	MCLPAM1000

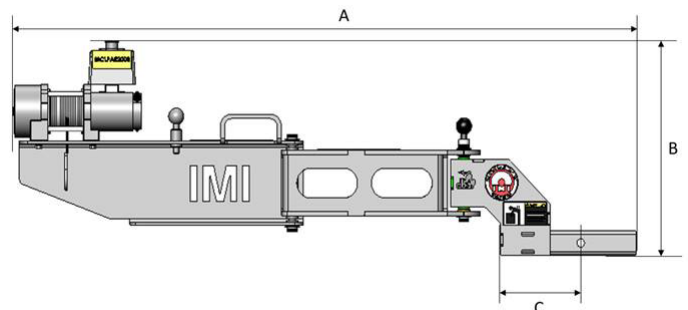
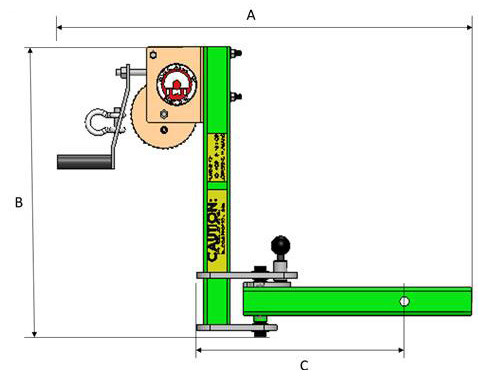

101 Metalworking Catalog

Wide variety of magnetic and related products for workholding, lifting, fixturing, clamping and material handling applications.

Material Handling

» MAGNETS «



INDUSTRIAL MAGNETICS.
EST. 1961

magnetics.com

101A3
MAGNETS, METALWORKING & MATERIAL HANDLING CATALOG

SEPARATION MAGNETS

SEPARATION MAGNETS FOR PRODUCT PURIFICATION AND EQUIPMENT PROTECTION



FREE FLOW



PNEUMATIC FLOW



LIQUID FLOW



OVER THE BELT



TRAMP METAL GROUP OVERVIEW - 304M

304 Tramp Metal Catalog

Industrial strength magnetic separation equipment for the removal of ferrous and non-ferrous metal contaminants from dry and liquid product flows.

GENERAL MAGNET SERVICE AND REPAIR



Thousands of Walker magnets are in service today performing safe, efficient material handling applications. Like any other type of industrial equipment, they should be maintained properly for optimum safety and performance. Worn contact surfaces, loose or broken cam-links, weld cracks, worst of all, illegible or missing labels and nameplates are common problems with older magnets. After years of use, worn bottom surfaces may not yield their original rated lift capacities. After reconditioning, IMI calibrates the bottom surfaces to ensure that they yield their original rated lift capacities. Don't wait until your magnet has an expensive breakdown requiring emergency repairs. IMI will inspect your magnet and controls and advise what repairs are needed. Before proceeding with your repairs, you'll receive an accurate estimate of the cost for your approval.

All IMI authorized repairs will carry a full 12-month warranty on the work performed. IMI reconditions other manufacturers' heavy lift, material handling and separation equipment. Equipment found to be in need of inspection/repair should be taken out of service and scheduled for inspection and repair at the IMI facility.



LIFT MAGNET SERVICE AND REPAIR

Safety consultants often say, "It's always better to prevent an accident than to defend your responsibility for one." Now is the time to inspect your lift magnets. Contact IMI to recondition or repair your magnet so it's as good as the day it was put into service.

- STEP 1:** The first step in the repair process is a complete incoming inspection. This inspection process includes both a mechanical and electrical evaluation. The magnet is assigned a job number and a "Magnet Service Report" is initiated.
- STEP 2:** The magnet is disassembled by machining or a controlled arc process. The parts are then inspected, noting those needing reconditioning or replacement. At this point a quotation is prepared and sent to the customer.
- STEP 3:** After the quotation has been approved by the customer, mechanical parts are cleaned and sand blasted in preparation for reassembly.
- STEP 4:** If required, the copper or aluminum conductor is then cleaned and inspected, noting any that are out of specification or needing replacement. Failure to replace conductor with the proper width and thickness leads to premature failure.
- STEP 5:** Engineering creates a CAD drawing for the production department along with a detailed bill of materials for the store room.
- STEP 6:** Coils are wound turn by turn with Nomex insulation in between each turn. When winding aluminum, the last three turns are wound with copper conductor.
- STEP 7:** After winding, the coil is tied off with vertical straps of copper. Alcuplate is used to join the aluminum conductor to the last two turns of copper conductor. This is one of the crucial steps that differentiates Walker Magnetics from other repair facilities. Alcuplate prevents galvanic corrosion and we are the only manufacturer to use this quality material.
- STEP 8:** Components are inspected against OEM drawings and remanufactured to the latest revision. Following a machining process, the magnet is ready for reassembly.
- STEP 9:** After the coil is installed in the case and properly insulated, the bottom plate is inserted and pressed to 4000 psi and tack welded. The magnet is then semi-automatically welded using stainless steel weld to permanently create a water tight seal.
- STEP 10:** The magnet is filled with a specially formulated insulating potting compound and baked to over 350 degrees F to produce a water tight fit and cure the potting compound.
- STEP 11:** In this final stage, all magnets are electrically tested. The values are recorded to create a historical record in the customer's individual folder.
- STEP 12:** Prior to shipment, the magnet is painted and the chains and pins are attached. The completed magnet is ready for shipment or to be put in a customer's individual Magnet Exchange Program inventory.
- STEP 13:** Walker delivers the highest quality New or Remanufactured magnet to your facility.



INDUSTRIAL MAGNETICS®

MAKING THINGS
BETTER®

Has Your Lift Magnet Been Tested?

Lift Magnets cannot be visually inspected alone. Lift Magnet Failure is often the result of internal damage to the magnetic material and is not evident by simple visual inspections that can be performed on other lifting devices.

Our Lift Magnet Testing and Certification Service performs both a thorough visual inspection and functional testing of your magnetic lifting products using testing techniques and equipment that meet the ASME B30.20 Standards for Below-the-Hook Magnetic Lifting Devices.

After testing, we provide documentation of the testing and a certificate of conformance if the magnet meets the manufacturer's labeled Working Load Limit (WLL) rating. Damaged label replacement is also included for Industrial Magnetics Inc. labeled Lift Magnets.

COMMON FACTORS FOR LIFT MAGNET LOSS OF PERFORMANCE OR FAILURE

Blunt force impact such as dropping, or banging on, the lift magnet can cause fractures in the magnet material

1. High heat: If the magnet is exposed to temperatures above its' capabilities it will lose magnetism
2. Exposure to electrical fields, like generators or welding ground circuits, will result in loss of magnetism.
3. External factors that influence a lift magnet's performance are; nicks, scratches, gouges, rust, etc. to the contact surface of the lifter.



magnetics.com

1385 S M 75 • Boyne City, MI 49712
Phone: 231.582.3100 • 800.662.4638
Mag-Mate®: 888.582.0822
Automation: 888.582.0823

INDUSTRIAL MAGNETICS, INC. IS A PROUD MEMBER OF:



Where market leaders grow

LIFTING SOLUTIONS CATALOG - 2020

Distributed By: