



INSTALLATION AND OPERATIONS MANUAL

P.O. #: Order #: Part #:

Operating Principle

Our Drawer-In-Housing magnetic separators, also known as Drawer Magnets or Grate In Housings, consist of two or more rows of round magnetic tubes that are assembled into drawers. The magnetic tubes of each row are aligned on alternating centers from the row directly above or below it. As product flows into the top of the housing, it is forced to cascade in a zig-zag pattern from row to row over the magnetic tubes. This ensures maximum tramp metal capture since the product comes in direct and repeated contact with a magnet as it travels through the housing.

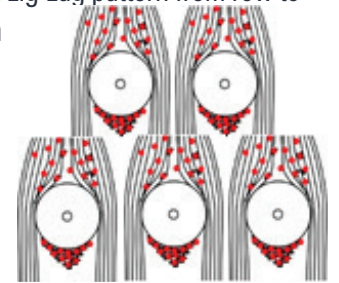

As ferrous metal passes through the magnetic field, it is held to the tubes and separated from the product. Captured tramp metal is held on the tubes until cleaning is initiated or activated; cleaning needs to be performed on a regular basis to eliminate buildup and prevent wash-off back into the product flow - see Cleaning Guidelines.

Optional Configurations

Drawer-In-Housing magnetic separators can be configured as **SimpleClean™**, **EZ-Clean**, **Self-Clean** or **Continuous Clean**, and can be designed in **Large Tube** or **Ox Heavy Duty** arrangements. Descriptions are below with illustrations shown on the following page.

SimpleClean™ units are manually opened for drawer access and tube wipe-down; each tube features a non-magnetic end section outside of the product flow to simplify cleaning/removal of tramp metal.

EZ-Clean units are designed to simplify the cleaning process: when manually opening the drawer the tubes are pulled through a stripper plate with wiper seals that clear the tramp metal from the tubes. The debris falls into a collection tray.

Self-Clean units feature valve-actuated pneumatic cylinders which open and close the drawer, clearing tramp metal in the same manner as the EZ-Clean design. Selector switches or other actuators can be provided to operate the control valve.

Continuous Clean units are designed to fully automate the cleaning process without the need to stop product flow. Multiple drawers on alternating cleaning cycles maintain magnetic separation at all times; the air-actuated cleaning action discharges tramp metal into a leak proof enclosure with a discharge chute.

Large Tube Housing® units are powerful magnetic separators that incorporate three inch diameter rare earth tubes into the proven Drawer-In-Housing configuration. The spacing between the tubes is much greater than in traditional housings, allowing for difficult-flowing product to move freely through the housing.

The Ox® Heavy Duty Drawer-In-Housing unit incorporates design elements that are essential for reliable performance under challenging processing conditions such as abnormal temperature and humidity, bridging, abrasion, corrosion or galling. The Ox® incorporates Nedox coated magnet tubes, Hydex wiper seals, heavier gage housings and larger air cylinders.

Fit and installation to customer process lines can be accommodated with **custom flanges and transitions**, optionally configured as round, square or angled at inlet and outlet.



Optional Configurations

The standard **IMH** Drawer-In-Housing can be configured in each of the four cleaning options:

- **SimpleClean™**
- **EZ-Clean**
- **Self-Clean**
- **Continuous Clean**



Simple Clean™ Drawer-In-Housing

The **LTH** Large Tube Housing® can also be configured in each of the four cleaning options:

- **SimpleClean™**
- **EZ-Clean**
- **Self-Clean**
- **Continuous Clean**

The **OXH** Heavy Duty Drawer-In-Housing can be configured optionally as:

- **EZ-Clean**
- **Self-Clean**
- **Continuous Clean**



Self-Clean Drawer-In-Housing

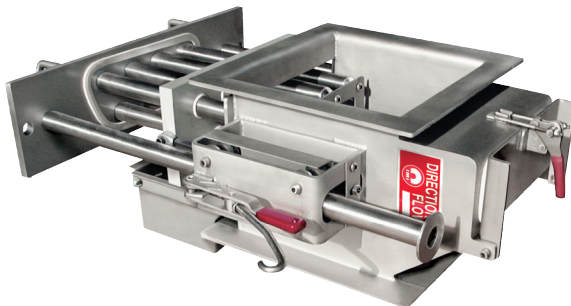

EZ-Clean Drawer-In-Housing

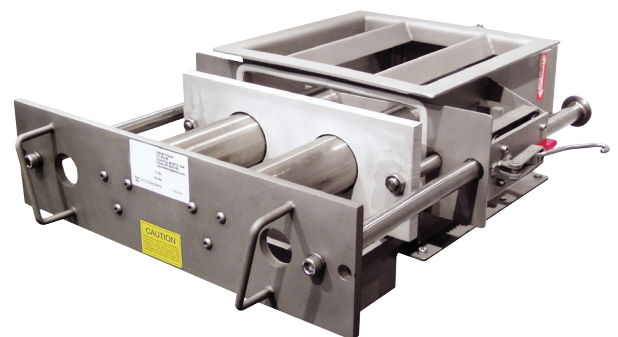

Large Tube EZ-Clean Drawer-In-Housing



Continuous Clean Drawer-In-Housing



Health and Safety Warnings

General



Please be advised that in and around the application of magnetic equipment, there are potential safety concerns that can arise with sensitive medical devices:



- » Pacemaker behavior can be affected when they are near strong magnetic fields
- » Medical implants and external fixation systems can be influenced by magnetic fields
- » Hearing aid behavior may be affected when exposed to strong magnetic fields

Any individual that carries the above equipment or other sensitive medical devices should use caution when they are around or handling magnets. For more specific information the wearer should contact their physician.



Beware of pinch points from sudden attraction and unexpected movement between magnets and ferrous metal equipment components or tools.



Electric shock hazard (Self-Clean units) - observe all local plant Lockout/Tagout procedures before removing any guards or initiating service or cleaning activity.

Cleaning Operations - Take precautions during cleaning operations:



Ensure that product flow has been shut off to avoid airborne irritants and/or product contamination



Avoid pinch points between the magnet and housing when opening and closing the unit



Use a rag or gloved hand for manual cleaning to avoid cuts or abrasions from tramp metal

Magnet Degradation

The force of a permanent magnet can degrade over time and when subjected to external influences. The most common factors for loss of performance or failure include:

- » Blunt force impact such as dropping or banging on a magnet which can cause fractures
- » Temperatures exceeding the operating range of the magnet material
 - » 180°F for neodymium material
 - » 480°F for ceramic grade 8
 - » High temperature options are available
- » Exposure to electrical fields like generators, lightning or welding ground circuits can result in loss of magnetism

It is recommended that magnetic devices are audited annually. IMI can provide a Magnet Audit and Plant Survey to evaluate magnetic equipment performance and assist with compliance to global industry standards; Pull Test Kits are available for self-auditing plant activity.





Installation

----- General for all Drawer-In-Housings -----

Magnetic separation devices use a magnetic field to attract, separate, and capture ferromagnetic particles from non-ferromagnetic material.

The Drawer-in-Housing must be installed to allow sufficient space for preventive maintenance and tramp metal removal. Allowance must be made for the drawer movement during the cleaning cycle.

The top and bottom flanges allow for the unit to be welded or bolted into the product flow. If the unit is to be bolted into place, stainless steel bolts are required. If the flanges have not been pre-drilled for bolt installation, any drill bit suitable for 304 stainless steel will do a quality job. **A minimum 3/8" diameter bolt is recommended.**

Final Magnets are magnetic separation devices which are designed to be installed at the last possible point in a food handling process. This should be immediately preceding a process step which will render the material un-flowable or immediately before the packaging process. Final magnets should be installed upstream of metal detectors and X-Ray equipment and downstream of pumps, augers or other machinery which could generate or proliferate ferromagnetic particles.

----- Self Clean Specific -----

The Air-Actuated, Self-Cleaning Drawer-in-Housing magnetic assembly comes ready to install.

The unit requires 0.15 - 0.30 SCFM of shop air at 80 to 100 psi depending on the frequency of magnet cleaning operation. The filter regulator is located on one side of the Housing assembly. The standard, electrically operated, spring-return solenoid valve requires a 120 VAC/60 Hz single phase power source to operate. The solenoid is energized via a user supplied, normally open (NO) switch. A momentary push-button is typically used in many applications. Pushing the button opens the drawer, cleaning the unit. Releasing the button removes power from the solenoid, allowing the drawer to close.

The cable from the solenoid contains three conductors: black, white & green. To be connected as follows:

Black or Brown - Connected to **switched** leg of 120 VAC supply circuit

White or Blue - Connected to **neutral** leg of 120 VAC supply circuit

Green or Green/Yellow - Connected to **ground** bus of circuit

Solenoid Specifications:

Coil -120V/60 Hz - 110V/50 Hz, 4.0-4.8 VA, rated for continuous duty at 85%-105% of rated voltage. Enclosure rated for NEMA 6P/IP67. Molded with three pin plug-in 11mm mini-DIN connector.

Cable - 6 ft (2 m) lg., 18GA/3 conductor cord, 0.27 in dia. (2.9 mm) O.D. PVC Jacket.

Coil Resistance:

79 KOhms cold, DC resistance; measure with a Digital Multimeter (DMM) connected to black & white leads.

Self Cleaning Pneumatic Schematic

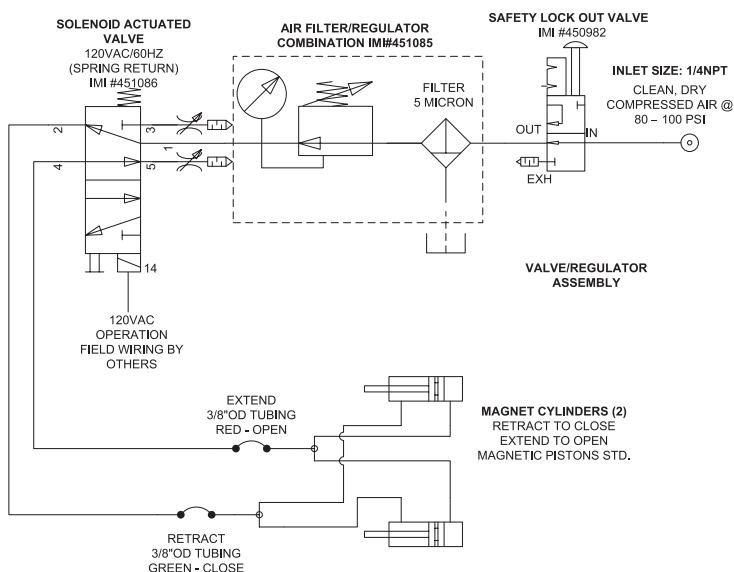

Self Cleaning Electrical Schematic

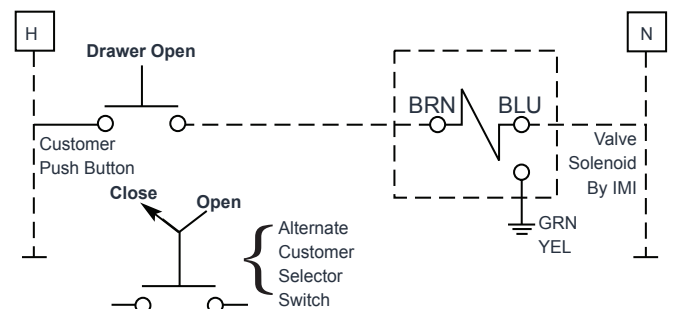



Installation - Continuous Clean

----- Continuous Clean Specific -----

The continuous-clean Drawer-in-Housing allows removal of tramp metal from the product stream while the product is flowing through the magnet. The enclosed guard assembly reduces the amount of product and dust released to the surrounding area. The cylinder-actuated drawers open and close on an adjustable, timed cycle to clean tramp metal from the magnetic tubes. Tramp metal is collected in a catch pan located below the drawers.

The air-actuated, continuous-clean Drawer-in-Housing magnetic assembly comes ready to install.

Pneumatic - The magnet requires 0.15 - 0.30 SCFM of clean, dry, shop air at 80-100 PSI and a 120VAC power source. Air is connected to a common point on the magnet. The pipe size is 1/4NPT, 3/8NPT or 1/2NPT depending upon the size of the drawers. Consult the magnet drawing for your application to determine the actual pipe size.

Electrical - The furnished solenoid valves and limit switches are factory connected to a junction box on the side of the magnet. A control enclosure is shipped loose for installation near the magnet. The controller is to be connected to the magnet junction box with a control cable or conduit and wire supplied by the user. Refer to the electrical and pneumatic schematics for more detail.

Two solenoid valves are provided. Typical specifications are as follows:

follows:

The cable from the solenoid contains three conductors: black, white & green. To be connected as follows:

Black or Brown - Connected to **switched** leg of 120 VAC supply circuit

White or Blue - Connected to **neutral** leg of 120 VAC supply circuit

Green or Green/Yellow - Connected to **ground** bus of circuit

Solenoid Specifications:

Coil -120V/60 Hz - 110V/50 Hz, 4.0-4.8 VA, rated for continuous duty at 85%-105% of rated voltage. Enclosure rated for NEMA 6P/IP67. Molded with three pin plug-in 11mm mini-DIN connector.

Cable - 6 ft (2 m) lg, 18GA/3 conductor cord, 0.27 in dia. (2.9 mm) O.D. PVC Jacket

Coil Resistance:

7.9 KOhms cold, DC resistance; measure with a Digital Multimeter (DMM) connected to black & white leads.

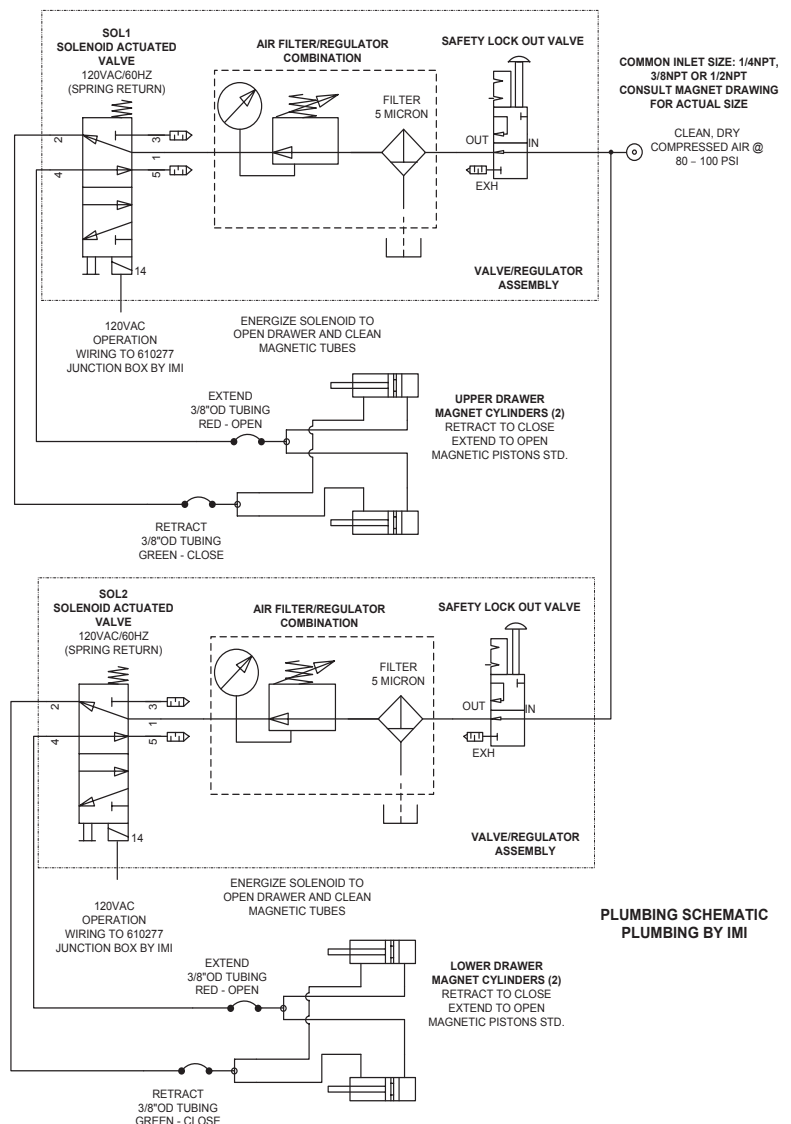



Control Overview - Continuous Clean

The control system for the typical, two-drawer, Continuous Clean Drawer-In-Housing, consists of two separate enclosures, one being a control panel, and the second, a junction box.

Control panel

The NEMA 4X fiberglass enclosure contains time delay, pulse counter and control relays and a terminal block. This panel is shipped loose for remote installation by the user. Requires 120VAC/60 Hz, hard-wired, power connection. The user is also to furnish an appropriate cable or conductors in conduit (16awg, 9 conductors) to connect the control panel to the junction box. The two time-delay relays are user adjustable according to observed tramp metal contamination and product flow rates. One of the time delay relay dials controls the cycle time between upper drawer cleanings (minutes to hours), the second dial determines the length of time the solenoid energizes to open the top drawer (seconds). The timer/counter relay counts how many times (typical is 3 cycles) the top-drawer cycles open then closed before the bottom drawer is allowed to open. The counter relay also has a time delay function that is used to determine the length of time (seconds) the solenoid energizes to open the bottom drawer.

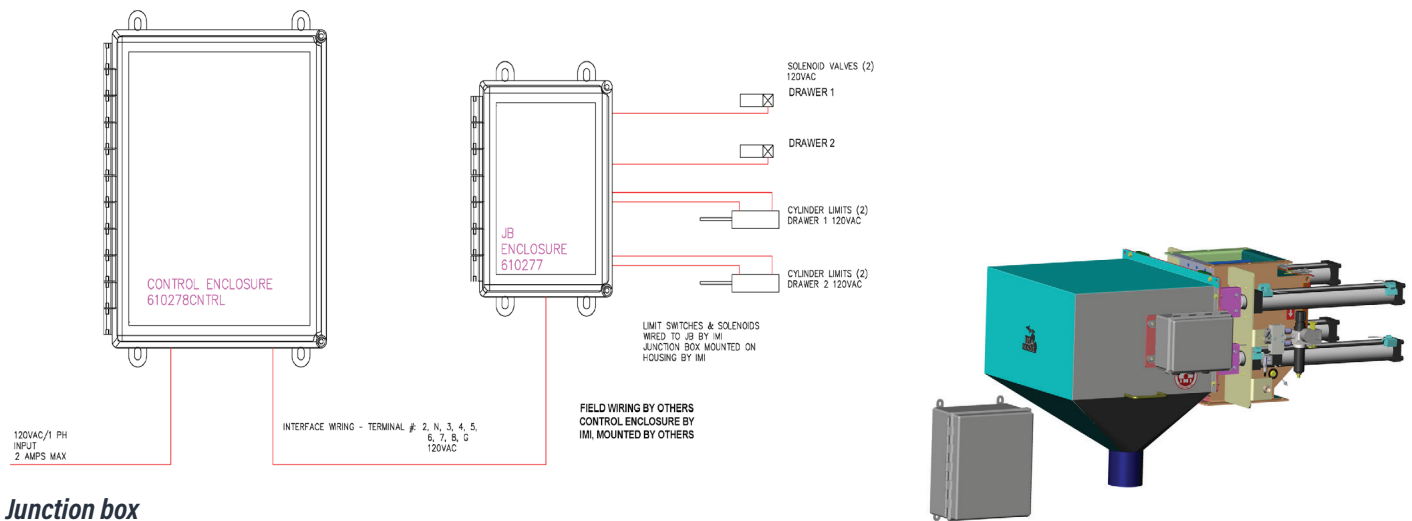

Junction box

NEMA 4X fiberglass enclosure containing a terminal strip. This junction box is factory installed on the magnet housing. The cables from the drawer valve solenoids (2) and cylinder reed limit switches (4) are factory wired to this strip using liquid tight cord grip strain reliefs.

Cylinder Limit switches

Furnished to signal drawer open & close positions. The upper drawer closed position is used to increment the counter relay. The closed limit switches are used, in conjunction with control relays, to lock out the drawer opening function. This is to prevent both drawers from being open at the same time. The upper drawer closed switch is interlocked in the lower drawer control circuit and the lower drawer closed switch is interlocked in the upper drawer control circuit.

Cleaning Cycle - Continuous Clean

To initiate the cleaning cycle, apply power to the control panel. The cycle will commence with a time delay (TDR1, t1), drawers closed. At the end of the delay, the top drawer will open for a time period (TDR1, t2) just long enough to allow complete opening of the top drawer. The drawer will then close. Upon closing, the counter (TRDC) is incremented. The drawers will remain closed according to the next time cycle (again determined by TDR1, t1). The top drawer may cycle open and close several times. Upon reaching a pre-determined number of counts (TDRC, c1), TDC will initiate a drawer open sequence of the bottom drawer (duration determined by TDC, t1). This time is to be just long enough to allow complete opening of the bottom drawer. Interlocks (CR1 and CR2) will keep both drawers from opening at the same time. Upon the closing of the bottom drawer, TDR1 will re-commence the cycle for the drawers.



Cleaning Guidelines and Procedures

It is recommended that cleaning frequency is scheduled such that magnetic build-up does not exceed 1mm of fines covering up to 50% of a magnetic surface. The recommended cleaning interval is at least twice in an 8-hour shift. Note: Cleaning frequency is dependent on the amount of tramp metal being separated from the product; if heavy concentrations of tramp metal are detected additional cleaning is necessary. When cleaning, ensure that the product flow has been shut off and that the magnet assembly is empty.

----- *SimpleClean™ (Manual Clean) Procedures* -----

1. Ensure that the product flow has been shut off and that the drawer assembly is empty.
2. Release clamps on side of housing.
3. Open door & pull drawer assemblies out, one at a time, using the finger holes.
4. Use a rag/gloved hand to wipe the collected tramp metal down to the back end of the tubes where a non-magnetic area (on SimpleClean) allows for most collected material to easily fall away or to be wiped off of the tubes.
5. Inspect gaskets for any damage, residual tramp metal or if they are pulling away from the mounting surface (see Gasket Maintenance page 8).
6. Place drawer assembly(s) back into the housing.
7. Re-clamp the door into the closed position.
8. Restart the product flow.

----- *EZ Clean Procedures* -----

1. Ensure that the product flow has been shut off and that the drawer assembly is empty of product.
2. Release clamps on side of housing; door will spring open approximately 2½ inches.
3. Open the drawer, sliding the tube assemblies through the wiper seals located in the seal plate. The door moves to the doorstop of the housing on the surface of the magnetic tubes via operator supplied force (the force required to open the drawer is directly proportional to the amount of metal collected on the magnetic tubes). At the front of the housing the collected tramp metal moves beyond the magnetic portion of the tube and falls free of the tubes into the provided catch pan.
3a. Tube-over-tube configuration: Open the drawer, sliding the tube assemblies through the over-tube sleeves. As the magnetic tube assemblies slide through the over-tubes, collected tramp metal moves along the over-tubes toward the seal plate and falls free of the over-tubes when the non-magnetic end of the magnetic tubes reach the seal plate.
4. Inspect gaskets for any damage, residual tramp metal or if they are pulling away from the mounting surface (see Gasket Maintenance page 8).
5. Re-clamp the door into the closed position.
6. Restart the product flow.

----- *Self Clean Procedures* -----

1. Ensure that the product flow has been shut off and that the drawer assembly is empty of product.
2. Activate the air cylinders by energizing solenoid valve. This opens the drawer, sliding the tube assemblies through the wiper seals located in the seal plate (or through the over-tubes in the tube-over-tube configuration, see 3a above). The wiper seals clean the collected metal off the tubes while the drawer opens, by pushing it on to a non-magnetic section at the ends of the tubes. The metal then falls off the tubes and into the provided catch pan.
3. Periodically inspect gaskets for any damage, residual tramp metal or if they are pulling away from the mounting surface (see Gasket Maintenance page 8).
4. After the drawer is fully extended and stops, de-energize the solenoid valve. The air cylinders will then close the drawer for operation.
5. Restart the product flow.

Important note:

Compressed air must be supplied to the Filter-Regulator at all times to ensure that the drawer remains in the closed position during both operation (product flowing) and idle times. Failure to supply compressed air during these times can result in possible product escaping the unit and/or contaminants entering the product flow area. consult Our engineering department if the air supply cannot be guaranteed and the drawer must remain closed.

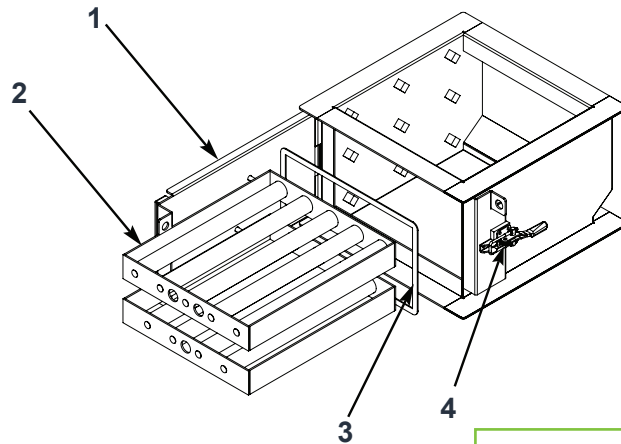

ILLUSTRATION & PARTS

Manual Clean

Ref. No. & Description

- 1. Access Door
- 2. Magnetic Grate Tube Assembly
- 3. Door Gasket
- 4. Door Clamp



Pictured: Manual Clean Housing

EZ & Self Clean

Ref. No. & Description

- 1. Wiper Seal
- 2. Seal Plate
- 3. Magnetic Tube Assembly
- 4. Door Gasket
- 5. Guide Rod Bolts (EZ Only)
- 6. Cylinder Bolts (SC Only)
- 7. Tube Assembly Bolts
- 8. Tube Front Plate
- 9. Guide Rods (EZ Only)
- 10. Cylinder Rods (SC Only)
- 11. Catch Pan
- 12. Spring
- 13. Cylinder (SC Only)
- 14. Guard Assembly (SC Only)
- 15. Door Clamp Assembly
- 16. Bearing Cover
- 17. Guide Bracket
- 18. Bearing Assembly
- 19. Cylinder Mount
- 20. Rear Access Door
- 21. Rear Door Clamp
- 22. Air Valve / Regulator Set (SC Only)
- 23. Rear Tube Plate

Pictured: Large Tube Housing

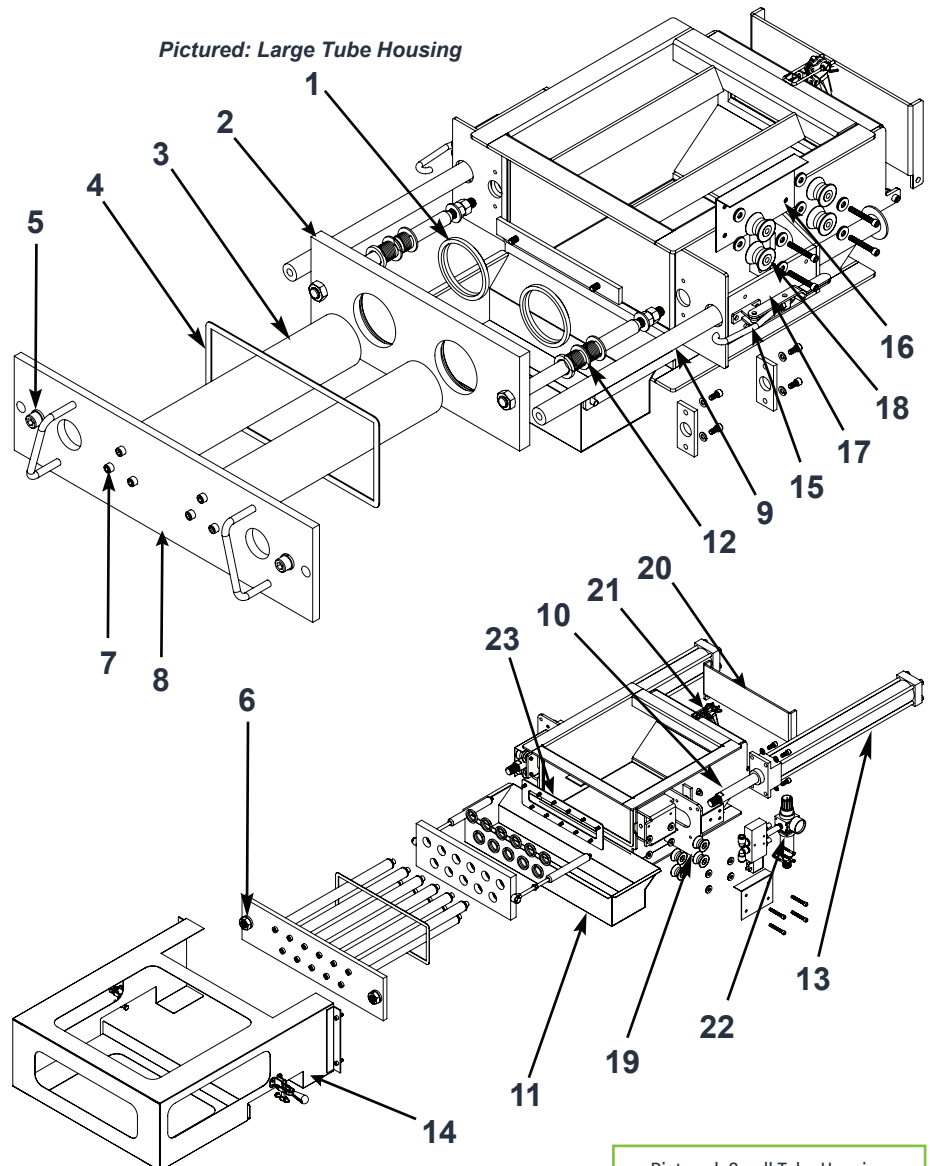

Pictured: Small Tube Housing

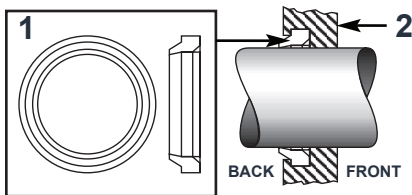

Seal Plate Shown with Seal Installed



WIPER SEAL REPLACEMENT

Wiper seals should be inspected for normal wear every three to six months to verify the integrity of the seal.

To replace worn out or damaged wiper seals:

----- EZ Clean Procedure -----

1. Open the drawer until it stops.
2. Unbolt the Springs (12) from the Seal Plate (2). Fasteners have been installed using thread locker. The use of a heat gun may be required to break loose the fastener.
3. Next remove the Guide Rod Bolts (5) from the Tube Front Plate (8). This separates the drawer assembly from the housing. Fasteners have been installed using thread locker. The use of a heat gun may be required to break loose the fastener.
4. Set the drawer assembly on a non-ferrous work surface and unbolt the Tube Assembly Bolts (7) and remove the Rear Tube Plate (23) from the tubes.
5. Slide the Seal Plate (2) off of the tubes. Magnet tubes may repel or attract each other when seal plate is removed. Use extreme caution to avoid injury. Place a non-ferrous spacer between rows and wrap tubes with wire ties or duct tape.
6. Push the worn out or damaged Wiper Seals (1) out of the Seal Plate (2).
7. Gently push new Wiper Seals (1) in.
8. After new seals are installed in the Seal Plate (2), reassemble the unit carefully, and check drawer travel to assure proper operation. Note: Magnet tubes are intended to have some movement to prevent binding. Apply temporary thread locker on the Tube Assembly Shoulder Bolt (7), snug them up to the Tube Front Plate (8), then loosen them each 1/4 of a turn. This will allow slight movement of the tube to prevent binding.

----- Self Clean Procedure -----

1. Remove Guard Assembly (14).
2. Activate Air Cylinders (13) to open the drawer until it stops.
3. For safety, turn off air supply to Regulator Valve Assembly (22).
4. Remove the Springs (12) from the Seal Plate (2). Fasteners have been installed using thread locker. The use of a heat gun may be required to break loose the fastener.
5. Remove the Cylinder Bolts (6) from Tube Front Plate (8). This separates the drawer assembly from the housing. Fasteners have been installed using thread locker. The use of a heat gun may be required to break loose the fastener.
6. Set the drawer assembly on a non-ferrous work surface and unbolt the Tube Assembly Bolts (7) and remove the Rear Tube Plate (23) from the tubes.
7. Slide the Seal Plate (2) off of the tubes. Magnet tubes may repel or attract each other when seal plate is removed. Use extreme caution to avoid injury. Place a non-ferrous spacer between rows and wrap tubes with wire ties or duct tape.
8. Push the worn out or damaged Wiper Seals (1) out of the Seal Plate (2).
9. Gently push new Wiper Seals (1) in.
10. After new seals are installed in the Seal Plate (2), reassemble the unit carefully, and check drawer travel to assure proper operation. Note: Magnet tubes are intended to have some movement to prevent binding. Apply temporary thread locker on the Tube Assembly Shoulder Bolt (7), snug them up to the Tube Front Plate (8), then loosen them each 1/4 of a turn. This will allow slight movement of the tube to prevent binding.

----- Optional Seals & Seal Retainers -----

Optional seals, for challenging applications such as high-temperatures, may be utilized with materials such as Hydex, brass or PTFE (Teflon), and may be retained with snap rings or seal retainer plates.

Follow disassembly procedures above to the point of sliding the Seal Plate off of the tubes (steps 1-7 for Self Clean).

- 8h. Remove retaining snap rings or retainer plate.
- 9h. Push the worn or damaged Seals out of the Seal Plate (2).
- 10h. Push new Seals into position in the Seal Plate (2).
- 11h. Replace snap rings or retainer plate.

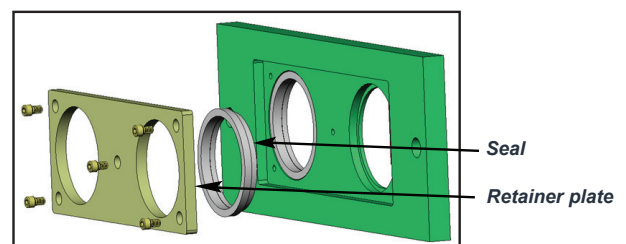
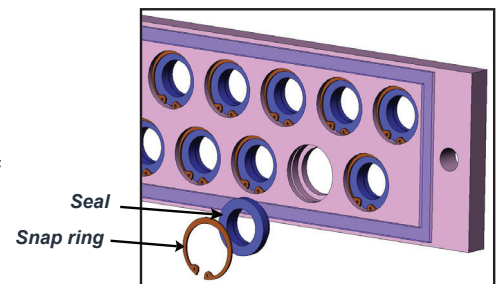



Gasket Maintenance

Inspect Gasket Material for wear and check to make sure that the gasket isn't pulling away from the housing when the door is being opened. Replace Gasket Material & Wiper Seals whenever wear is excessive or the Magnet Housing starts leaking. Call IMI for recommended Gasket Material.

To replace worn out or damaged Gasket Material:

Warning: *Wear protective gloves as blades and tools may become attracted to a nearby magnet.*

Note: this procedure is tailored for new gasket material delivered in strips with attached VHB tape.

1. Use a flat Razor to completely remove the old gasket and adhesive. Wipe surface with an appropriate solvent such as 3M 6040 Adhesive Remover
2. Measure, cut and layout the new gasket to ensure that the gasket will fit well.
3. Remove the clear film from the top of adhesive tape.
4. Place gasket onto exposed adhesive and press gasket firmly to ensure contact with tape and repeat for all sides.
5. Use a high quality silicone adhesive sealant to fill all seams around the gasket material (inside, outside and joints).
6. Press silicone into the seams and remove any excess. Ensure the top seams are filled.
7. Allow at least 8 hours for silicone to cure before closing or using the unit.

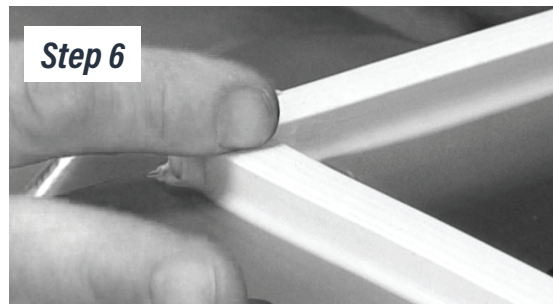
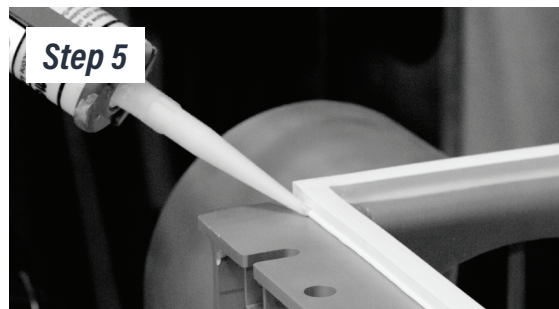
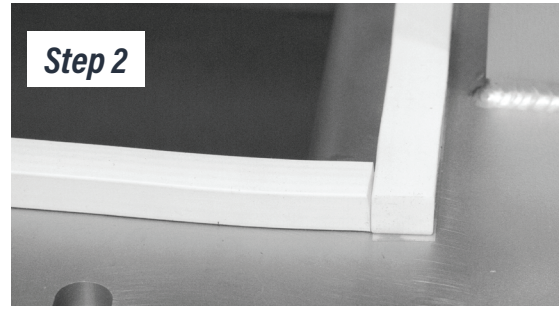

COMMENTS OR CONCERNS?

We believe Industrial Magnetics, Inc. offers the finest Drawer-in-Housing available today. Great pride has gone into the design and manufacture of this unit. Any comments or concerns should be directed to our Customer Service Department at 1-888-582-0821. We appreciate the opportunity to serve you!