



PLATE MAGNETS AND HUMP MAGNETS

INSTALLATION AND OPERATIONS MANUAL

OPERATING PRINCIPLE

Magnetic separation devices use a magnetic field to attract, separate, and capture ferromagnetic particles from non-ferromagnetic material.

Magnet devices can be utilized to separate contaminants from incoming raw materials, mid-process to protect equipment, or for final product purification. Final Magnets are magnetic separation devices which are designed to be installed at the last possible point in a product handling process. This should be immediately preceding a process step which will render the material un-flowable or immediately before the packaging process. Final Magnets should be installed upstream of metal detectors and X-Ray equipment and downstream of pumps, augers or other machinery which could generate or proliferate ferromagnetic particles.

Flush Face (FF) Plate Magnets are designed for above-the-flow applications to lift ferrous metal out of the product flow, protecting downstream equipment and product purity.

Exposed Pole (EP) Plate Magnets are designed for below-the-flow applications. The magnetic stainless steel poles provide added protection from wash-off without impeding product flow. Exposed pole models are ideal for low volume chute installations.

Spout Style (SM) Plate Magnets feature a diverter to provide maximum tramp metal separation for high volume below-the-flow applications. The diverter and magnetic stainless steel exposed poles provide added protection from collected metal wash off and product degradation without impeding product flow.

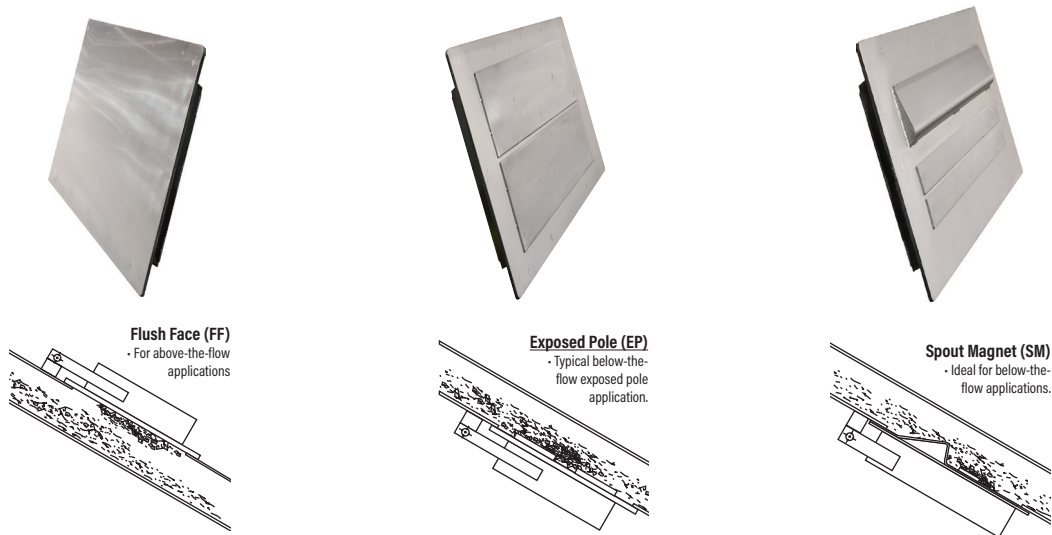

OPTIONAL CONFIGURATIONS

Plate magnets can be configured as **Manual Clean, EZ-Clean or Self-Clean**; each of these can be factory assembled into chutes as **Hump Magnets (Plate-In-Chute Separators)**. See the following pages for Installation and Cleaning Instruction detail.

Manual clean units can be easily opened to enable wipe down of the exposed magnetic surface.

EZ-Clean and Self-Clean units are designed to simplify the cleaning process: these cleaning options feature stripper plates that swing out of the product flow and away from the magnetic surface to release collected metal.

Hump Magnets are available as **Single Leg** units with one Plate Magnet or **Double Leg** with two Plate Magnets.



HEALTH AND SAFETY WARNINGS

GENERAL



Please be advised that in and around the application of magnetic equipment, there are potential safety concerns that can arise with sensitive medical devices:



- » Pacemaker behavior can be affected when they are near strong magnetic fields
- » Medical implants and external fixation systems can be influenced by magnetic fields
- » Hearing aid behavior may be affected when exposed to strong magnetic fields

Any individual that carries the above equipment or other sensitive medical devices should use caution when they are around or handling magnets. For more specific information the wearer should contact their physician.



Beware of pinch points from sudden attraction and unexpected movement between magnets and ferrous metal equipment components or tools.

CLEANING OPERATIONS - Take precautions during cleaning operations:



Ensure that product flow has been shut off to avoid airborne irritants and/or product contamination



Assess weight of the magnet to control movement when opening the unit



Avoid pinch points between the magnet and chute when opening and closing the unit



Use a rag or gloved hand for manual cleaning to avoid cuts or abrasions from tramp metal

MAGNET DEGRADATION

The force of a permanent magnet can degrade over time and when subjected to external influences. The most common factors for loss of performance or failure include:

- » Blunt force impact such as dropping or banging on a magnet which can cause fractures
- » Temperatures exceeding the operating range of the magnet material
 - » 180°F for neodymium material
 - » 500°F for ceramic grade 8
 - » High temperature options are available.
- » Exposure to electrical fields, like generators, lightning or welding ground circuits, can result in loss of magnetism

It is recommended that magnetic devices are audited annually. IMI can provide a Magnet Audit and Plant Survey to evaluate magnetic equipment performance and assist with compliance to global industry standards; Pull Test Kits are available for self-auditing plant activity.





INSTALLATION - MANUAL CLEAN AND EZ-CLEAN

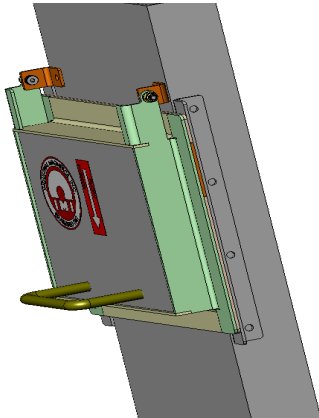

The Plate magnet assembly must be installed to allow sufficient space for preventive maintenance and tramp metal removal. Allowance must be made for magnet assembly movement during the cleaning cycle.

Chute angle is an important consideration for Plate Magnet installation. Standard units are designed to perform best at angles of 45° to 60° from horizontal.

CHUTE PREPARATION

1. Measure the size of the magnet or review the drawing of the magnet assembly to determine the size the opening required in the chute prior to cutting the hole in the chute.
2. If necessary, weld in place angles (included as option or supplied by customer) to the sides of the chute at the opening. Review drawing to determine the length of the angle.
3. IMI recommends that gasket material (included as option or supplied by customer) is applied to the perimeter of the opening. This will ensure that the chute is sealed when the unit is closed.

Note: Chute must be clean to bare metal and flat within 1/16" in order for gasket material to seal openi

MAGNET INSTALLATION

4. Align magnet assembly on chute and clamp into place.
5. Make sure the magnet face comes into complete contact with the gasket surface.
6. Tack weld or otherwise fasten the mounting angles and/or pivot blocks to the chute.
7. Release clamps on magnet assembly and swing magnet open; open and close to test pivot movement.

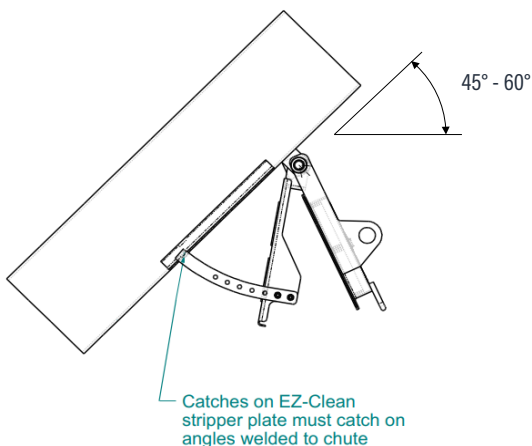
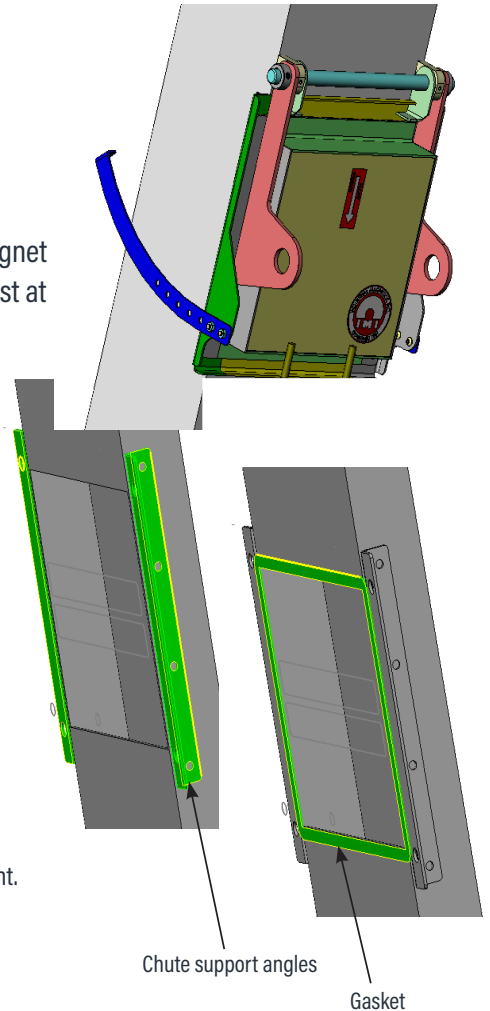

NOTE for EZ-CLEAN ONLY: Catches on stripper plate must catch on angles welded to chute.

8. Complete attachment of the mounting angles to the chute as required.
9. Attach permanent clamps (included as option or supplied by customer) to the chute. Suggested location is to clamp on the flange on the downstream end of the magnet assembly, opposite the hinge.
10. If lockout feature is to be used, drill hole in the installed angle in line with the provided hole in the magnet assembly flange. Insert lock shank through the holes.

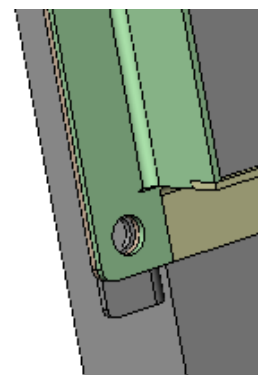



INSTALLATION - SELF CLEAN

The Plate magnet assembly must be installed to allow sufficient space for preventive maintenance and tramp metal removal. Allowance must be made for magnet assembly movement during the cleaning cycle.

CHUTE PREPARATION

Measure the size of the magnet or review the drawing of the magnet assembly to determine the size of the opening required in the chute prior to cutting the hole in the chute.

If necessary, weld in place angles (included as option or supplied by customer) to the sides of the chute at the opening. Review drawing to determine the length of the angle.

IMI recommends that gasket material (included as option or supplied by customer) is applied to the perimeter of the opening. This will ensure that the chute is sealed when the unit is closed.

Note: Chute must be clean to bare metal and flat within 1/16" in order for gasket material to seal opening.

PRE ASSEMBLY OF CYLINDER

Bolt the cylinders to the cylinder mount angles with the bolts provided.

Connect the cylinder pivot pins to the cylinder angles with the shoulder bolts provided.

MAGNET INSTALLATION

Align magnet assembly on chute and clamp into place.

Make sure the magnet face comes into complete contact with the gasket surface.

Tack weld or otherwise fasten the pivot blocks to the chute.

Release any clamps on magnet assembly and swing magnet open; open and close to test pivot movement.

Note that the catches on the stripper plate must catch on angles/flanges on the chute.

CYLINDER INSTALLATION

Position the cylinders to the chute per location on the drawings.

Connect the clevises to the magnet bar or magnet pivot pins with the provided shoulder bolts.

Tack weld the cylinder pivot and gusset (if equipped) to the chute.

Manually pull the magnet through the open and close cycles.

Adjust the location of the cylinder pivots as required to allow the magnet to be closed and still have 1/4 to 1/2 inch of cylinder travel available.

Complete attachment of the cylinder pivot to the chute as required.

PNEUMATICS

Locate and mount the solenoid valve and filter/regulator.

Connect air lines according to the pneumatic schematic on page 7.

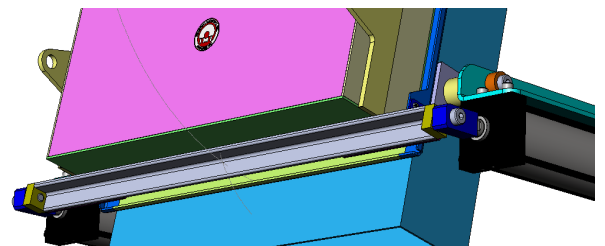
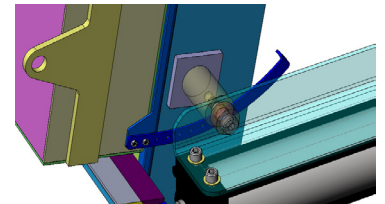
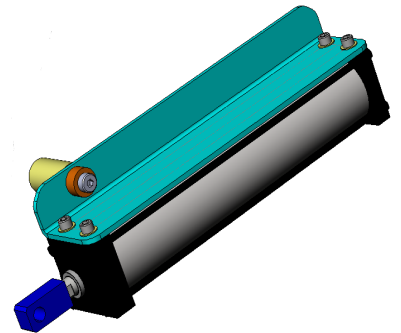
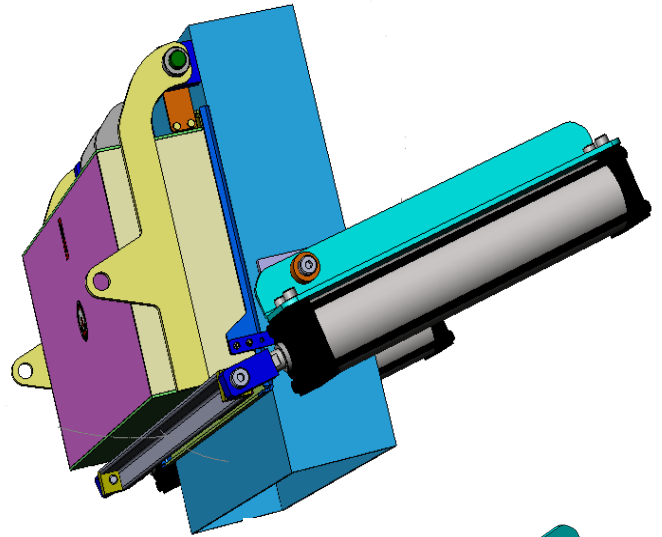



INSTALLATION - HUMP MAGNETS

Hump Magnet separators are constructed with hinged Plate Magnets gasketed and clamped tightly to the hump housing. Hump Magnets are arranged into either round pipe or rectangular chute assemblies to fit directly into plant processing lines. Top and bottom transitions are typically designed for bolted flange installation, and can be alternately configured with transitions to suit a preferred installation method.

HUMP MAGNET INSTALLATION:

1. Measure overall height of the Hump unit from top to bottom transitions.
2. Confirm suitable location in the process line.
3. Construct appropriate line space for the Hump unit overall height; allow for gasket thickness if planned at transitions.
4. Position Hump assembly in location with transition points matched up to upstream and downstream process equipment.
5. Clamp, tack weld or otherwise temporarily secure Hump unit in place. Provide appropriate superstructure support for the unit and the connected process lines.
6. Release any clamps on magnet assembly and swing magnet open; open and close to test pivot movement. Refer to details on the previous pages for specific instructions according to Plate Magnet configuration.
7. Complete permanent installation framing.

PNEUMATICS:

Locate the solenoid valve and filter/regulator; reposition if desired from factory location.
Connect air lines according to the pneumatic schematic on page 7.



Single Leg Hump Magnet with
Self-Clean Spout Plate Magnet



Double Leg Hump Magnet with two
EZ-Clean Spout Plate Magnets



CLEANING GUIDELINES

It is recommended that cleaning frequency is scheduled such that magnetic build-up does not exceed 1mm of fines on up to 50% of a magnetic surface. The recommended cleaning interval is at least twice in an eight (8) hour shift. Note: cleaning frequency is dependent on the amount of tramp metal being separated from the product flow; if heavy concentrations of tramp metal are detected additional cleaning is necessary. When cleaning, ensure that the product flow has been shut off and that the magnetic assembly is empty.

CLEANING OPERATION - MANUAL and EZ-CLEAN

PROCEDURE:

1. Ensure that the product flow has been shut off
2. Unlock if the Lock-out feature is employed.
3. Release clamps to swing magnet assembly open. Caution: assess magnet weight to control movement.
4. EZ-Clean: observe position of the stripper plate as the adjustable catches limit travel: confirm suitable position for wiping and collecting debris, adjust as required.
5. Use a rag/gloved hand to wipe the collected tramp metal particles off the magnetic surface or stripper plate
Note: for Flush Face above-the-flow installations: take care that the debris does not fall into the chute opening and cause contamination in the product flow.
6. Inspect gasket for any damage, residual tramp metal, or if it is pulling away from the chute
7. Swing magnet assembly closed; re-clamp and visually inspect for effective seal
Lock-out as required
8. Restart the product flow

CLEANING OPERATION - SELF CLEAN

Cleaning the magnet involves activating the cylinders to fully open the magnet. The tramp metal collected on the stripper plate will stay on the magnet until the catches bottom out. The magnet will move away from the stripper plate allowing the tramp metal to fall off.

Procedure:

1. Ensure that the product flow has been shut off
2. Activate the solenoid to actuate full cylinder travel.
3. Observe position of the stripper plate as the adjustable catches limit travel: confirm suitable position for collecting debris, adjust as required.
4. De-activate the solenoid to close the magnet.
5. Restart the product flow once the magnet is completely closed.

MAINTENANCE - MANUAL AND EZ-CLEAN

Maintenance for Manual and EZ-Clean Plate Magnets is limited to periodic inspection of gaskets and hinge pivots and planning for replacement or repair if wear or damage is indicated.

MAINTENANCE - SELF CLEAN

Cylinders, valves and solenoids require normal pneumatic maintenance.
Replace gasket material when required.



ELECTRICAL SCHEMATIC - SELF CLEAN

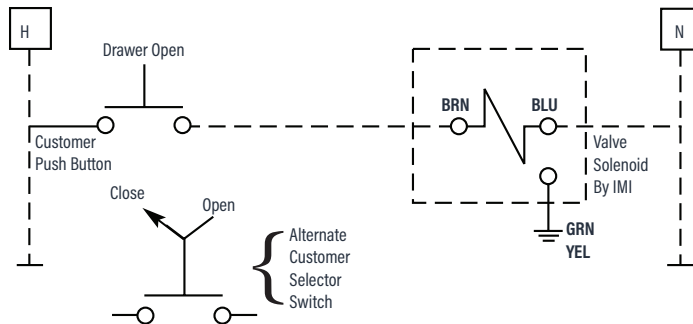

PNEUMATIC SCHEMATIC - SELF CLEAN

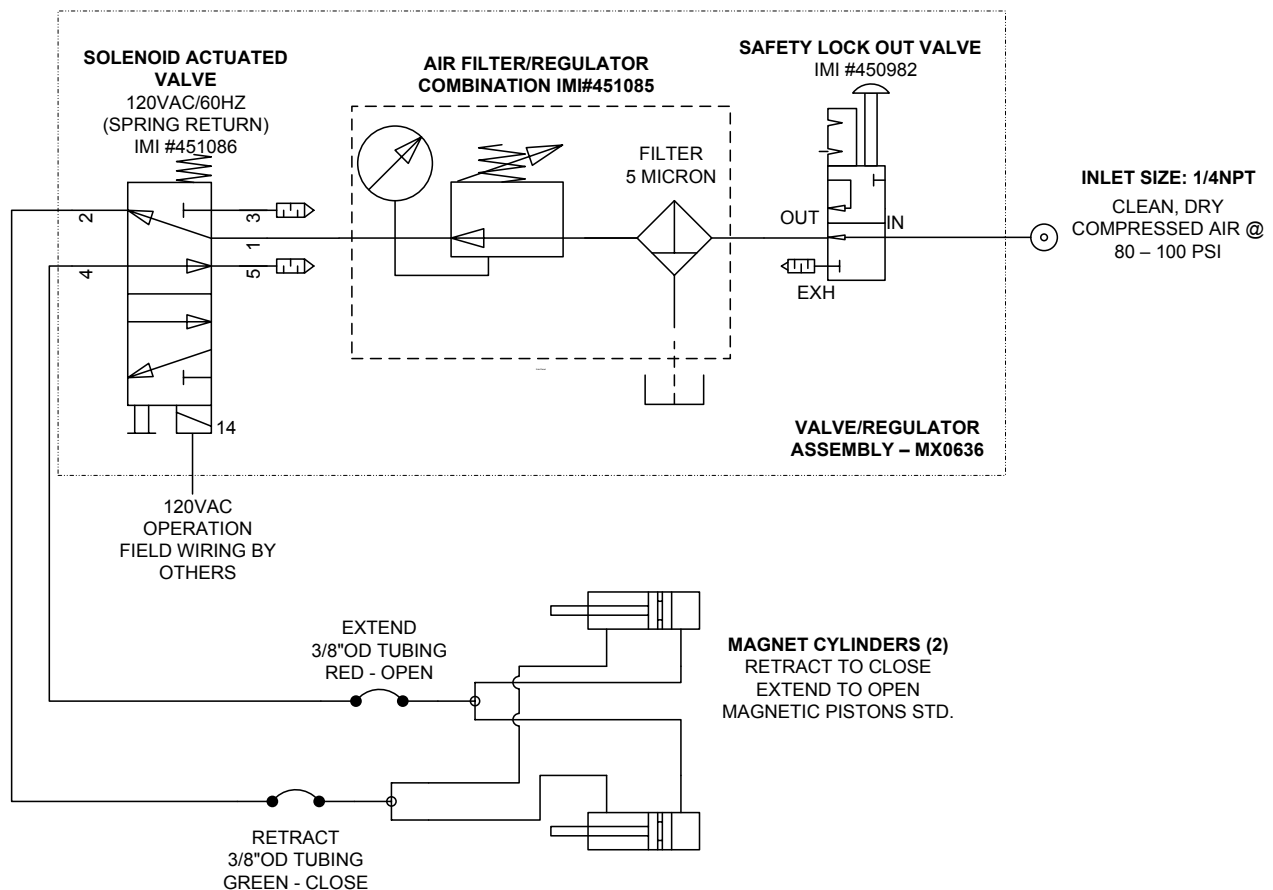

COMMENTS OR CONCERNS?

We believe Industrial Magnetics, Inc. offers the finest Plate Magnets available today. Great pride has gone into the design and manufacture of this unit. Any comments or concerns should be directed to our Customer Service Department at 1-888-582-0821.

We appreciate the opportunity to serve you!



INDUSTRIAL MAGNETICS.

TOLL FREE 1.800.662.4638 imi@magnetics.com