



PNEUMATIC LINE MAGNETS • BULLET, EP TUBE & PLH INSTALLATION MANUAL

Operating Principle

IMI Pneumatic Line Magnets are designed to capture ferrous and weakly magnetic particles from material flow in dilute phase pneumatic line systems operating at or below 15 psi. Pneumatic Line Magnets can be installed vertically, horizontally, or at an angle. There are three models available: Bullet Magnets, Exposed Pole (EP) Tube magnets and Pneumatic Line Housings.

The Bullet Magnet features leak-resistant seals, Easy Clean stripper collar, door mounted magnet with aerodynamic stainless steel nose cone (removes magnet from product flow for cleaning) and overall stainless steel construction.

The Exposed Pole (EP) Tube Magnet is an open flow design with the magnetic elements built into the body of the housing; the ceramic magnet version has the magnets in the stationary sides of the housing, the rare earth tubes feature door mounted magnets.

The Pneumatic Line Housing (PLH) incorporates a series of one-inch diameter rare earth tubes on staggered centers positioned in the product flow. This ensures that all product flowing through the housing comes in repeated contact with the magnets. The PLH can be configured as EZ-Clean or Self-Clean with pneumatic cylinder actuation for the cleaning cycle.

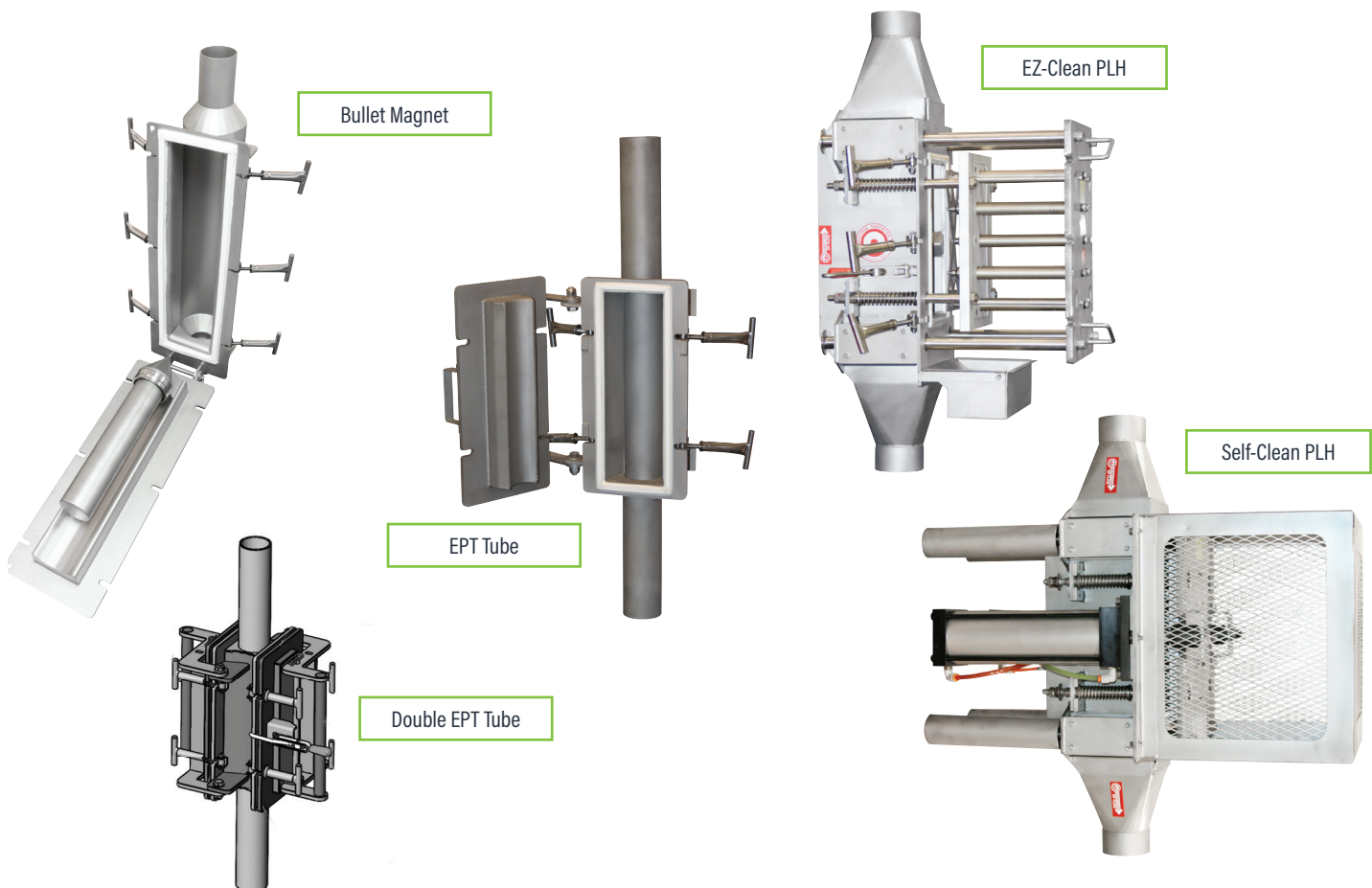



Health and Safety Warnings

General



Please be advised that in and around the application of magnetic equipment, there are potential safety concerns that can arise with sensitive medical devices:



- » Pacemaker behavior can be affected when they are near strong magnetic fields
- » Medical implants and external fixation systems can be influenced by magnetic fields
- » Hearing aid behavior may be affected when exposed to strong magnetic fields

Any individual that carries the above equipment or other sensitive medical devices should use caution when they are around or handling magnets. For more specific information the wearer should contact their physician.



Beware of pinch points from sudden attraction and unexpected movement between magnets and ferrous metal equipment components or tools.



Electric shock hazard (Self-Clean units) - observe all local plant Lockout/Tagout procedures before removing any guards or initiating service or cleaning activity.

Cleaning Operations - Take precautions during cleaning operations:



Ensure that product flow has been shut off to avoid airborne irritants and/or product contamination



Avoid pinch points between the magnet and housing when opening and closing the unit



Use a rag or gloved hand for manual cleaning to avoid cuts or abrasions from tramp metal

Magnet Degradation

The force of a permanent magnet can degrade over time and when subjected to external influences. The most common factors for loss of performance or failure include:

- » Blunt force impact such as dropping or banging on a magnet which can cause fractures
- » Temperatures exceeding the operating range of the magnet material
 - » 180°F for neodymium material
 - » 480°F for ceramic grade 8
 - » High temperature options are available
- » Exposure to electrical fields like generators, lightning or welding ground circuits can result in loss of magnetism

It is recommended that magnetic devices are audited annually. IMI can provide a Magnet Audit and Plant Survey to evaluate magnetic equipment performance and assist with compliance to global industry standards; Pull Test Kits are available for self-auditing plant activity.





CLEANING GUIDELINES

It is recommended that cleaning frequency is scheduled such that magnetic build-up does not exceed 1mm of fines on up to 50% of a magnetic surface. The recommended cleaning interval is at least twice in an 8-hour shift.

Note: Cleaning frequency is dependent on the amount of tramp metal being separated from the product; if heavy concentrations of tramp metal are detected additional cleaning is necessary. When cleaning, ensure that the product flow has been shut off and that the magnetic assembly is empty.

----- *Pneumatic Line Housing EZ-Clean* -----

1. Ensure that the product flow has been shut off and that the assembly is empty of product.
2. Release clamps on side of housing.
3. Pull open the drawer, sliding the tube assemblies through the wiper seals located in the seal plate. For proper cleaning, the door and seal plate must be pulled fully open until they stop (the force required to open the drawer is directly proportional to the amount of metal collected on the magnetic tubes). At the front of the housing the collected tramp metal moves beyond the magnetic portion of the tube and falls free of the tubes into a collection tray.
4. Push the drawer closed and latch the clamps hand-tight to reseal for operation.

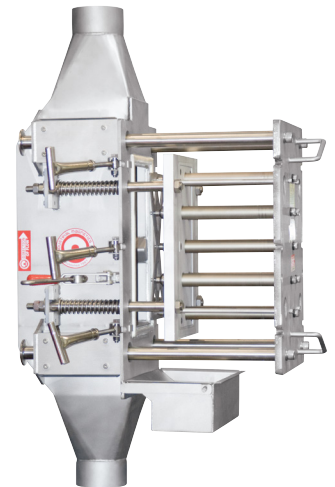

----- *Pneumatic Line Housing Self-Clean* -----

1. Ensure that the product flow has been shut off and that the assembly is empty of product.
2. Activate the air cylinders by energizing solenoid valve. This opens the drawer, sliding the tube assemblies through the wiper seals located in the seal plate. The wiper seals clean the collected metal off the tubes while the drawer opens, by pushing it on to a non-magnetic section at the ends of the tubes. The metal then falls off the tubes and into the provided catch pan.
3. After the drawer is fully extended and stops, de-energize the solenoid valve. The air cylinders will then close the drawer for operation.
4. Restart the product flow.

NOTE: Compressed air must be supplied at all times to ensure drawer remains in the closed position during operation.

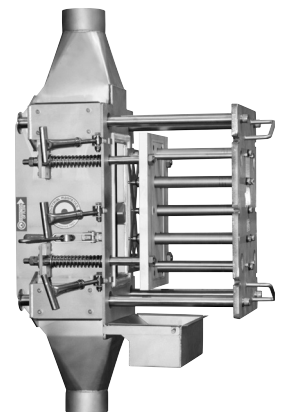



----- Bullet® Magnet -----

1. Ensure that the product flow has been shut off and that the assembly is empty of product.
2. Unlatch the door clamps while holding the door closed.
3. Carefully swing the door open, supporting the weight of the door and magnet.
4. Pull the stripper collar off and dispose of tramp metal that falls off of the collar as it leaves the magnetic field.
5. Wipe off the magnetic tube with a shop rag or gloved hand to remove any tramp metal particles that may remain.
6. Inspect the gasket for excessive wear.
7. Return the stripper collar on the magnetic tube.
(Magnet end of collar must be touching back-side of Nose Cone)
8. Close door and latch the clamps hand-tight to reseal the Bullet Magnet for operation.



----- Exposed Pole Tube Magnet -----

1. Ensure that the product flow has been shut off and that the assembly is empty of product.
2. Unlatch the door clamps and remove or open the door.
3. Wipe off the magnetic surface with a shop rag or gloved hand to remove any tramp metal particles.
4. Inspect the gasket for excessive wear.
5. Set the door back on the housing / close the door and latch the clamps hand-tight to reseal the EP-Tube Magnet for operation.

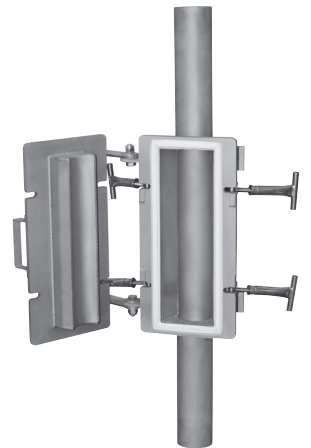

----- Double Exposed Pole Tube Magnet -----

1. Ensure that the product flow has been shut off and that the assembly is empty of product.
2. When opening the first door of a dual exposed pole tube magnetic assembly (EPT), first undo the t-handle clamps and swing them to the side or out of the way
3. Proceed to swing the handle of the main destaco clamp, however, do not disengage the hook of the clamp (Caution, the magnets are repelling each other).
4. To disengage the hook of the clamp, push the door closed and then undo the hook (at the same time keeping pressure on the door assembly) then swing door assembly open.
5. Wipe off the magnetic surface with a shop rag or gloved hand to remove any tramp metal particles.
6. Inspect the gasket for excessive wear.
7. To close, push the door closed until the hook of the clamp is engaged and close the main destaco clamp, then reengage the t-handle clamps.
8. Repeat steps 2 through 7 for the second door.

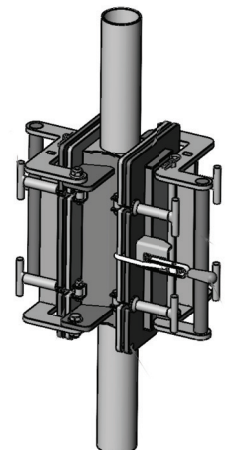



INSTALLATION

Pneumatic Line Magnets can be easily installed with compression couplings. Standard magnets are built with plain tube or pipe ends. Cam locks and ANSI Flanges can be provided upon request. The magnet is supported from the ends by the connections to the pneumatic lines. The magnet must be installed with adequate space for the door to swing open for cleaning. IMI's Pneumatic Line Magnets are designed and tested to operate at up to 15 PSI.

Final Magnets are magnetic separation devices which are designed to be installed at the last possible point in a food handling process. This should be immediately preceding a process step which will render it un-flowable or immediately before the packaging process. Final magnets should be installed upstream of metal detectors and X-Ray equipment and downstream of pumps, augers or other machinery which could generate or proliferate ferromagnetic particles.

Pneumatic Line Magnets can be installed vertically, horizontally, or at an angle. **Vertical Position will allow product to drain from the magnet area when the system is shut down.**

Note: Diagram to the right is for Bullet Magnet. Vertical Mounting is recommended for EP-Tubes & Pneumatic Line Housing.

For Placement of a pneumatic line magnet near a curve: Magnet should be located 10 times the line diameter away from the curve, measured in inches.
Example: 10 X 4" line = 40" from curve.

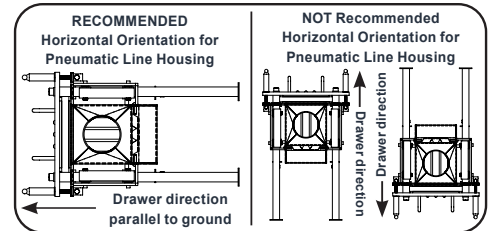
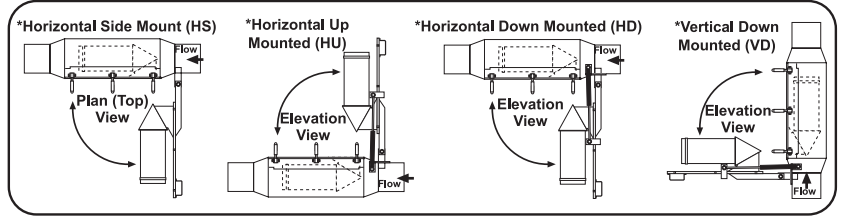

----- Self Clean PLH Specific -----

The Air-Actuated, Self-Cleaning Pneumatic-Line-Housing magnetic assembly comes ready to install.

The unit requires 0.15 - 0.30 SCFM of shop air at 80 to 100 psi depending on the frequency of magnet cleaning operation. The filter regulator is located on one side of the Housing assembly. The standard, electrically operated solenoid valve requires a 120 VAC/60 Hz single phase power source to operate. The solenoid is energized via a user supplied, normally open (NO) switch. A momentary push-button is typically used in many applications. Pushing the button opens the drawer, cleaning the unit. Releasing the button removes power from the solenoid, allowing the drawer to close.

The cable from the solenoid contains three conductors: blue, brown & green/yellow. To be connected as follows:

- Brown** - Connected to **switched** leg of 120 VAC supply circuit
- Blue** - Connected to **neutral** leg of 120 VAC supply circuit
- Green/Yellow** - Connected to **ground** bus of circuit

Solenoid Specifications:

Coil -120V/60 Hz - 110V/50 Hz, 7.0 Watts, Class H insulation, Rated for continuous duty at 90%-105% of rated voltage. Enclosure rated for NEMA 4/IP 65 per DIN 40050. Molded with three pin plug-in connector.

Cable - 5 ft lg., 3 conductor cord, equivalent to 18/3 SVT

920 ohms cold, DC resistance Measure with a Digital Multimeter (DMM) connected to brown & blue leads

Coil Resistance:

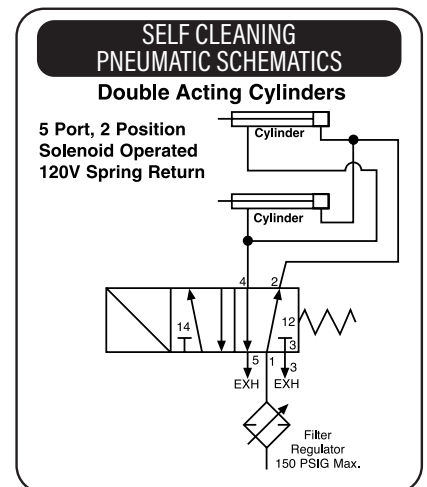
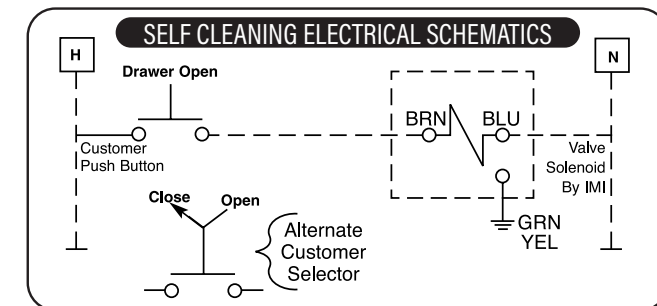



Gasket Maintenance

Inspect Gasket Material for wear and check to make sure that the gasket isn't pulling away from the housing when the door is being opened. Replace Gasket Material & Wiper Seals whenever wear is excessive or the Magnet Housing starts leaking. Call IMI for recommended Gasket Material.

To replace worn out or damaged Gasket Material:

Warning: Wear protective gloves as blades and tools may become attracted to a nearby magnet.

Note: this procedure is tailored for new gasket material delivered in strips with attached VHB tape.

1. Use a flat Razor to completely remove the old gasket and adhesive. Wipe surface with an appropriate solvent such as 3M 6040 Adhesive Remover
2. Measure, cut and layout the new gasket to ensure that the gasket will fit well.
3. Remove the clear film from the top of adhesive tape.
4. Place gasket onto exposed adhesive and press gasket firmly to ensure contact with tape and repeat for all sides.
5. Use a high quality silicone adhesive sealant to fill all seams around the gasket material (inside, outside and joints).
6. Press silicone into the seams and remove any excess. Ensure the top seams are filled.
7. Allow at least 8 hours for silicone to cure before closing or using the unit.

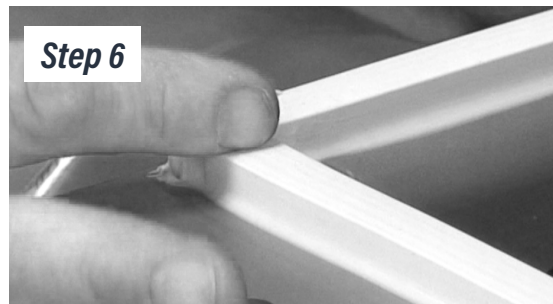
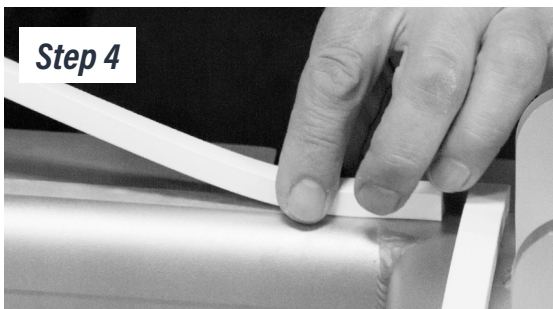
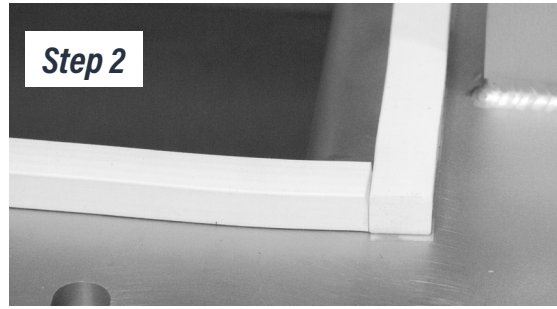



PLH Wiper Seal Replacement

Wiper seals should be inspected for normal wear every three to six months to verify the integrity of the seal.

To replace worn out or damaged wiper seals:

----- EZ-Clean Procedures -----

1. Open the drawer until it stops.
2. Remove the Jam Nuts (6) that connect the Seal Plate Guide Rods (3) to the Seal Plate (2).
3. Remove the Front Plate Guide Rod Bolts (5) from the Tube Front Plate (4). This separates the drawer assembly from the housing.
4. Set the drawer assembly on a non-ferrous work surface and Slide the Seal Plate (2) off of the tubes.
5. Push the worn out or damaged Wiper Seals (1) out of the Seal Plate (2).
6. Gently push the new Wiper Seals (1) in.
7. After new seals are installed in the seal plate reassemble the unit carefully, and check drawer travel to assure proper operation.

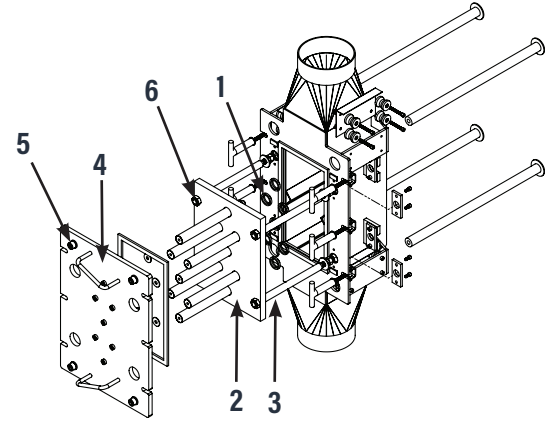

----- Self-Clean Procedures -----

1. Remove Guard Assembly (8).
2. Activate Air Cylinders (7) to open the drawer until it stops.
3. For safety, turn off air supply to Regulator Valve Assembly (9). Disconnect supply tubing from all cylinder ports.
4. Remove the Jam Nuts (6) that connect the Seal Plate Guide Rods (3) to the Seal Plate (2).
5. Remove the Jam Nuts that connect the Cylinder Rod Couplers (10) to the Drawer Assembly.
6. Remove the Front Plate Guide Rod Bolts (5) from the Tube Front Plate (4). This separates the drawer assembly from the housing.
7. Set the drawer assembly on a non-ferrous work surface and Slide the Seal Plate (2) off of the tubes.
8. Push the worn out or damaged Wiper Seals (1) out of the Seal Plate (2).
9. Gently push the new Wiper Seals (1) in.
10. After new seals are installed in the Seal Plate (2), reassemble the unit carefully, and check drawer travel to assure proper operation.

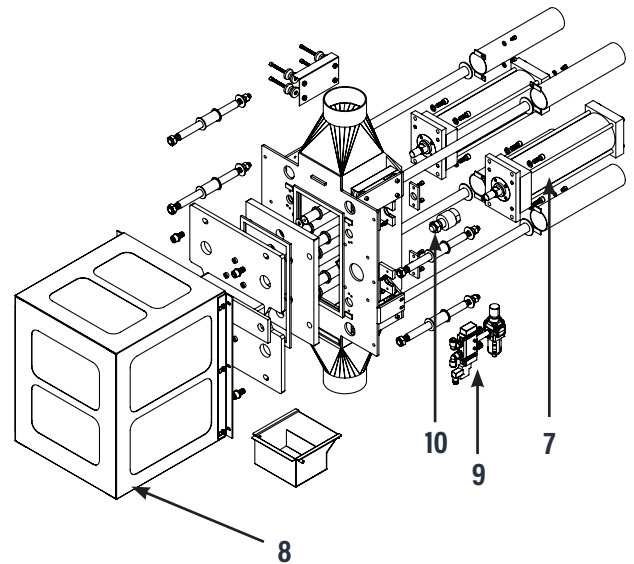

----- Parts List -----

Ref. No. & Description

1. Wiper Seals
2. Seal Plate
3. Guide Rods
4. Tube Front Plate
5. Guide Rod Bolts
6. Jam Nuts
7. Air Cylinders
8. Guard Assembly
9. Regulator Valve Assembly
10. Cylinder Rod Couplers

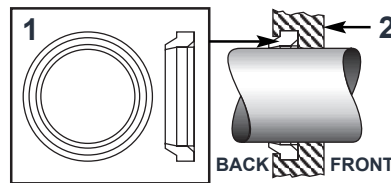

Seal Plate Shown with Seal Installed



PLH Wiper Seal Replacement (Continued)

----- *Optional Seals & Seal Retainers* -----

Optional seals, for challenging applications such as high-temperatures, may be utilized with materials such as Hydex, brass or PTFE (Teflon), and may be retained with snap rings or seal retainer plates.

Follow disassembly procedures above to the point of sliding the Seal Plate off of the tubes (steps 1-7 for Self Clean).

8h. Remove retaining snap rings or retainer plate.

9h. Push the worn or damaged Seals out of the Seal Plate (2).

10h. Push new Seals into position in the Seal Plate (2).

11h. Replace snap rings or retainer plate.

Reassemble and check as described above (step 10 for Self Clean).

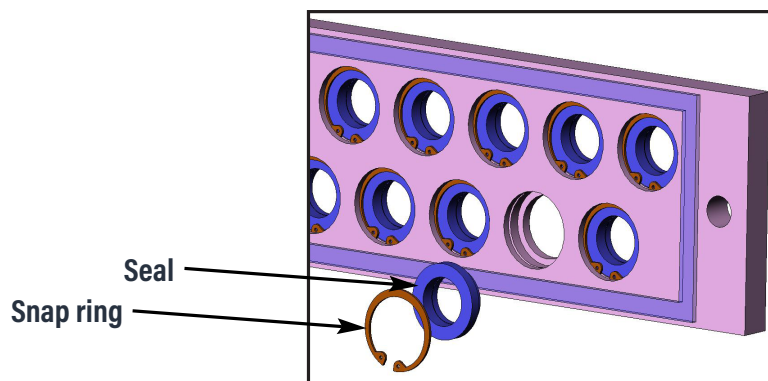

COMMENTS OR CONCERNS?

We believe Industrial Magnetics, Inc. offers the finest Pneumatic Line Magnets available today. Great pride has gone into the design and manufacture of this unit. Any comments or concerns should be directed to our Customer Service Department at 1-888-582-0821.

We appreciate the opportunity to serve you!