



MANHOLE COVER LIFT SYSTEM OPERATIONS MANUAL

Overview & Operating Principle

Single and Dual Magnet Systems

This cover lift system uses a unique adjustable four-position hook, and a four-position adjustable handle with four angle positions of 90°, 105°, 120° and 135°. An optional Spreader Bar facilitates the use of two lift magnets for large manhole covers. Once the handle and hook are positioned for use and the magnet(s) are affixed to the manhole cover, the system provides the leverage to enable single-user operation.

Maximum lift capacity 400 lbs.

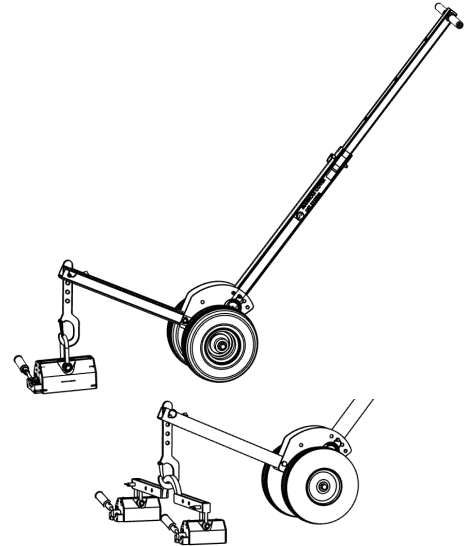

HEALTH AND SAFETY WARNINGS

GENERAL



Please be advised that in and around the application of magnetic equipment, there are potential safety concerns that can arise with sensitive medical devices:



- Pacemaker behavior can be affected when they are near strong magnetic fields
- Medical implants and external fixation systems can be influenced by magnetic fields
- Hearing aid behavior may be affected when exposed to strong magnetic fields



Any individual that carries the above equipment or other sensitive medical devices should use caution when they are around or handling magnets. For more specific information the wearer should contact their physician.



Beware of pinch points from sudden attraction and unexpected movement between magnets and ferrous metal equipment components or tools.

Beware of pinch points at the pivot, lift hook, and handle when adjusting Lift System positions.

Keep feet and other extremities out from beneath a lifted load.



DOLLY SETUP AND OPERATION

1. Unfold unit by pulling out Storage Pin (1) closest to the wheel and unfold the dolly. Replace the pin in any of the four alternate hole positions. Be sure coworkers and other equipment are clear of the area while unfolding the dolly. Refer to Figure 1.
2. Locate the lifting hook that is pinned and stored inside the dolly end. Remove the pin and pull the hook out. Replace the hook

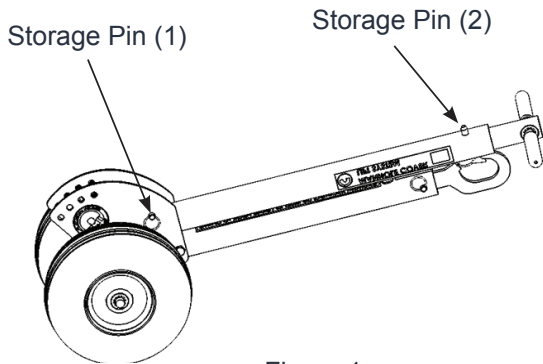

Figure 1

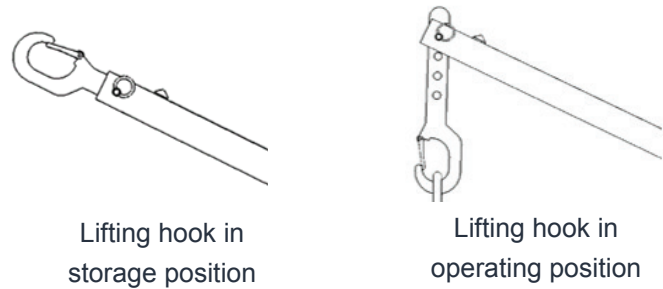

Figure 2

into the slots and insert the pin through the dolly and one of the middle two holes in the hook. See Figure 2.

3. Remove Storage Pin (2) on the handle and extend the handle to any of the three holes and replace the pin. The third hole position (longest handle) will provide the maximum leverage when lifting the manhole cover. Refer to Figure 1.
4. Reposition Storage Pin (1) to one of the four settings to optimize the handle position for the user's height. Refer to Figure 3. Attach the lifting magnet(s) to the dolly. Position the handles of the lift magnets away from the side where the dolly will be attached. Refer to Figure 4.

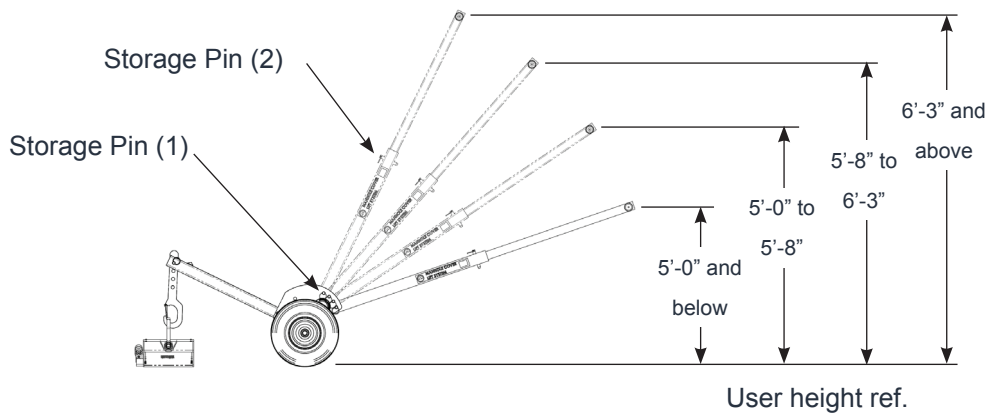

Figure 3

Note: Ideal setup position places the handle of the dolly just above the user's navel.



DOLLY SETUP AND OPERATION (CONT.)

- a. If using one magnet attach the lift lug of the magnet directly to the included hook on the dolly.
 - b. If using two magnets attach the spreader bar to the magnets by sliding the lift lugs into the slot on the spreader bar and pinning into place. Use the widest holes allowable for the manhole cover being lifted. Make sure the magnets are placed directly below the spreader bar holes and use the same hole on each side to keep the assembly balanced.
5. Verify that the manhole cover is clean of dirt and other debris. If the cover is packed with snow or ice use a tool of choice to clear it.
 6. Position magnets on the manhole cover See Figure 5 a) and b) below for the placement of one or two magnets. Magnets must fully contact the face of the manhole cover.
 7. Actuate the on/off handle on each magnet in use. There will be resistance in the handle until the "On" position is reached. **Note that the manhole cover must be loose before attempting lifting.**
 8. Once the magnet(s) are attached, fine tune adjustments can be made to operate the dolly in the most ergonomic and efficient manner. Ideal setup position places the handle of the dolly just above the user's navel. To achieve this height, adjust the angle of the handle or the length of the hook.

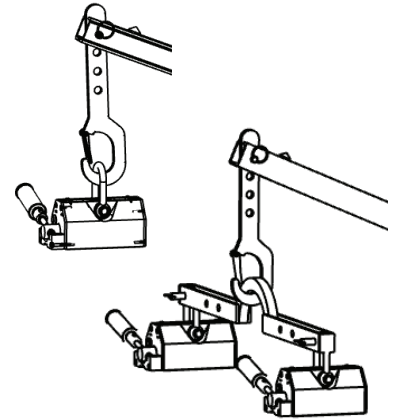

Figure 4

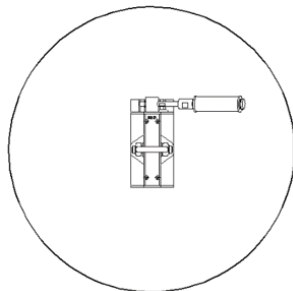

Figure 5a) Single magnet

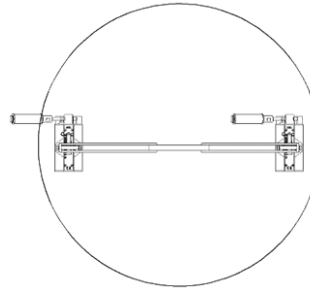

Figure 5b) Two magnets

9. To lift the manhole cover, push down on the handle. Walk manhole cover out of the way to access hole.
10. When finished, use dolly to replace the manhole cover. Turn off the magnet(s) and roll dolly away.
11. Return the dolly hook to the storage position and collapse the dolly into the folded position for storage.

COMMENTS OR CONCERNS?

We believe Industrial Magnetics, Inc. offers the finest Manhole Cover Lift System available today. Great pride has gone into the design and manufacture of this unit. Any comments or concerns should be directed to our Customer Service Department at 1-888-582-0821.

We appreciate the opportunity to serve you!