



PLATE-IN-CHUTE MAGNETIC SEPARATORS

HUMP MAGNETS

IMI plate magnets can be provided with engineered chutes to fit directly into your processing lines. Customer specified inlet and outlet requirements can be accommodated using custom designed housings, transitions (round or rectangular), flanges and more. Housings and chutes are available for single plate magnets, multiple plate magnets and for Manual, EZ or Self-Cleaning models.

EZ-Clean and Self Cleaning Spout Magnets

are designed to simplify the cleaning process and to increase processing line efficiency. These cleaning options feature spout faced stripper pans that swing out of the product flow and away from the magnet to release collected metal. The EZ-Clean unit is operated manually by unclamping the magnet and pulling the assembly into the open position. The Self-Cleaning model operates on the same principle but uses either pneumatic cylinders or electric actuators to open and close the plate magnet at user specified intervals. Standard units are designed for 45° to 60° chutes. Custom units available for other chute angles upon request.

Single-Leg Hump Magnets

Our Single Leg Hump Magnet is designed to be placed in product flows at angles 45° or less from horizontal. If angle of flow is greater than 45°, please contact IMI for the proper magnet.

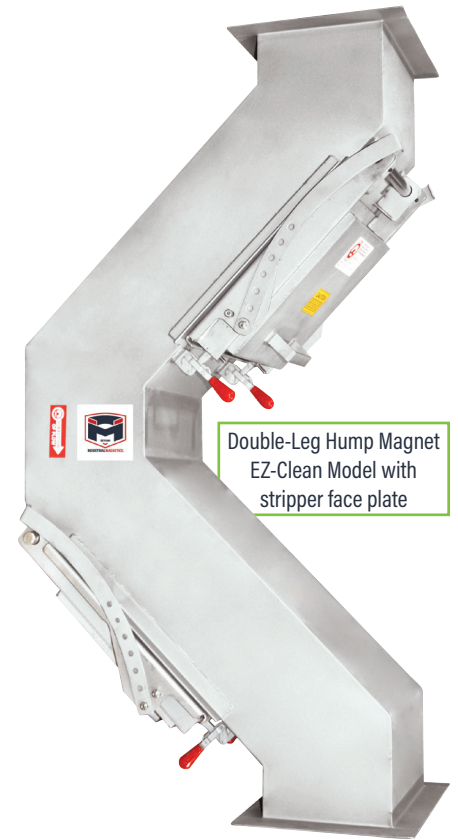

Double-Leg Hump Magnet
EZ-Clean Model with
stripper face plate

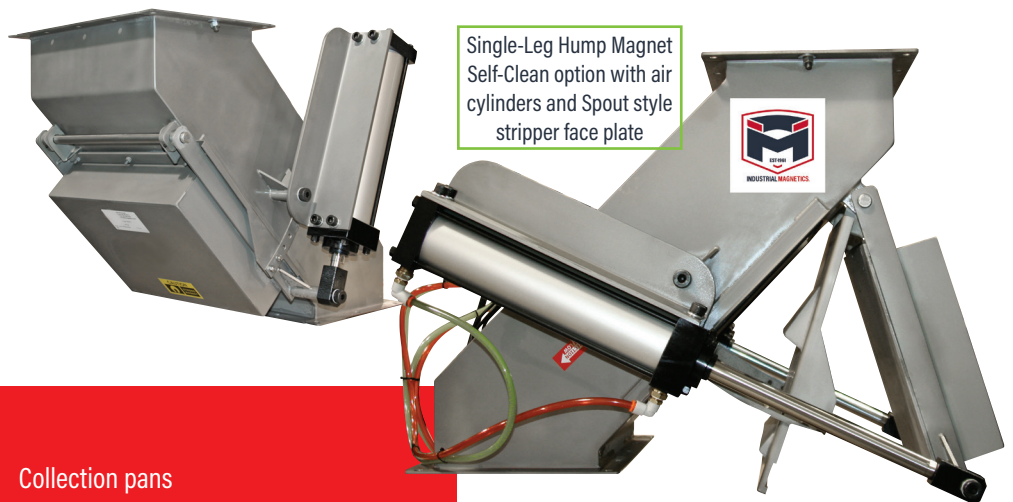

Single-Leg Hump Magnet
Self-Clean option with air
cylinders and Spout style
stripper face plate

FEATURES:

- » All T304 Stainless Steel construction
- » Ceramic or Rare Earth Magnets
- » Customary finish
- » DE-STA-CO clamps for a positive seal
- » Leak resistant seals

OPTIONS:

- » Mild steel construction
- » Food Grade Finish
- » Pre-drilled Flanges
- » Round inlet and outlet transitions
- » Rectangular or square transitions
- » Self-Cleaning designs
- » Collection pans
- » Metal guarding (Self-Cleaning)
- » Wear Resistant Linings
- » High Temp
- » EZ-Clean stripper design (recommended for all models)

 **HACCP International
Certified Equipment.**

Our **Sanitary Grade Hump Magnets** are certified by HACCP International and fully conform to HACCP International's Food Safety Standard (0909MAGSEP 1-2010) for direct contact with food product.

TOLL FREE 1.888.582.0821 imi@magnetics.com





Hump Magnet Specifications

DOUBLE-LEG - RECTANGULAR OPENINGS

MODEL NUMBER	REACH-OUT	MAGNET	CIRCUIT NAME	CHUTE DEPTH INSIDE D	CHUTE WIDTH INSIDE B	OFFSET C	HEIGHT H	FT3/HR.	APPROX. WEIGHT LBS.
H07X10R05	5	Rare Earth	R05	7	10	22.875	42	4,167	162
H07X12R05	5	Rare Earth	R05	7	12	22.875	42	5,000	194
H07X14R05	5	Rare Earth	R05	7	14	22.875	42	5,833	227
H07X20R05	5	Rare Earth	R05	7	20	22.875	42	8,333	324
H07X26R05	5	Rare Earth	R05	7	26	22.875	42	10,833	421
H07X34R05	5	Rare Earth	R05	7	34	22.875	42	14,167	550
H07X40R05	5	Rare Earth	R05	7	40	22.875	42	16,667	647
H08X10C06	6	Ceramic	C06	8	10	23.875	44	5,000	311
H08X12C06	6	Ceramic	C06	8	12	23.875	44	6,000	374
H08X14C06	6	Ceramic	C06	8	14	23.875	44	7,000	436
H08X20C06	6	Ceramic	C06	8	20	23.875	44	10,000	623
H08X26C06	6	Ceramic	C06	8	26	23.875	44	13,000	809
H08X34C06	6	Ceramic	C06	8	34	23.875	44	17,000	1058
H08X40C06	6	Ceramic	C06	8	40	23.875	44	20,000	1245

DOUBLE-LEG - ROUND OPENINGS

MODEL NUMBER	REACH-OUT	MAGNET	CIRCUIT NAME	INLET DIA. E	OFFSET C	HEIGHT H	FT3/HR.	APPROX. WEIGHT LBS.
H06DC06	6	Ceramic	C06	6	19-1/2	57	1,875	142
H08DC06	6	Ceramic	C06	8	21-1/2	57	3,281	174
H09DC06	6	Ceramic	C06	9	21-1/2	57	3,938	210
H10DC06	6	Ceramic	C06	10	21-1/2	57	4,594	245
H12DC06	6	Ceramic	C06	12	21-1/2	57	6,563	348
H14DC06	6	Ceramic	C06	14	21-1/2	57	8,531	452
H16DC06	6	Ceramic	C06	16	22-1/2	60	9,188	486
H18DC06	6	Ceramic	C06	18	23	60	12,750	589
H20DC06	6	Ceramic	C06	20	23	60	15,000	692

SINGLE-LEG - RECTANGULAR OPENINGS

MODEL NUMBER	REACH-OUT	MAGNET	CIRCUIT NAME	CHUTE DEPTH INSIDE D	CHUTE WIDTH INSIDE B	OFFSET C	HEIGHT H	FT3/HR.	APPROX. WEIGHT LBS.
HH07X8R05	5	Rare Earth	R05	7	8	22.875	21	3,333	65
HH07X12R05	5	Rare Earth	R05	7	12	22.875	21	5,000	97
HH07X13R05	5	Rare Earth	R05	7	13	22.875	21	5,417	105
HH07X14R05	5	Rare Earth	R05	7	14	22.875	21	5,833	113
HH07X18R05	5	Rare Earth	R05	7	18	22.875	21	7,500	146
HH07X60R05	5	Rare Earth	R05	7	60	22.875	21	25,000	485
HH08X8C06	6	Ceramic	C06	8	8	23.875	22	4,000	125
HH08X12C06	6	Ceramic	C06	8	12	23.875	22	6,000	187
HH08X13C06	6	Ceramic	C06	8	13	23.875	22	6,500	202
HH08X14C06	6	Ceramic	C06	8	14	23.875	22	7,000	218
HH08X18C06	6	Ceramic	C06	8	18	23.875	22	9,000	280
HH08X60C06	6	Ceramic	C06	8	60	23.875	22	30,000	934

SINGLE-LEG - ROUND OPENINGS

MODEL NUMBER	REACH-OUT	MAGNET	CIRCUIT NAME	INLET DIA. E	OFFSET C	HEIGHT D	FT3/HR.	APPROX. WEIGHT LBS.
HH06DC06	6	Ceramic	C06	6	14-1/2	35	1,875	71
HH08DC06	6	Ceramic	C06	8	14-1/2	35	3,281	87
HH09DC06	6	Ceramic	C06	9	14-1/2	35	3,938	105
HH10DC06	6	Ceramic	C06	10	14-1/2	35	4,594	123
HH12DC06	6	Ceramic	C06	12	14-1/2	35	6,563	174
HH14DC06	6	Ceramic	C06	14	14-1/2	35	8,531	226
HH16DC06	6	Ceramic	C06	16	14-1/2	37	9,188	295
HH18DC06	6	Ceramic	C06	18	14-1/2	37	12,750	295
HH20DC06	6	Ceramic	C06	20	14-1/2	37	15,000	346

NOTE:

- All Dimensions Are Stated In Inches. Ft3/Hr. based on 200 FPM at 75% full for Double-Leg models and 200 FPM at Max Reach-Out for Single-Leg models.
- All standard models listed in the tables are available with EZ-Clean or Self-Clean options. Append the letter E (for EZ-Clean) or S (for Self-Clean) to the end of the part numbers to order these options.

DOUBLE-LEG

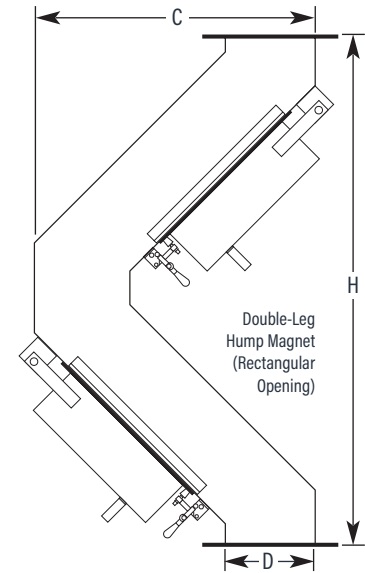

SINGLE-LEG

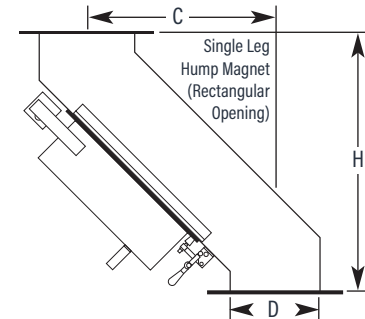

FLANGE AND OPENING

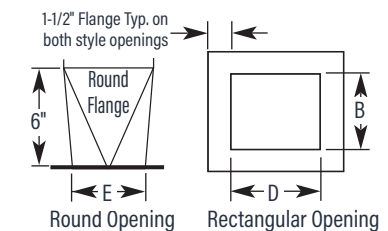

Need a Quote? Please fill out the **TG-01Q questionnaire** as completely as possible to ensure the proper magnet selection for your application.