



HIGH VOLUME SEPARATION EXTRACTOR MAGNETS

EZ-CLEAN & SELF-CLEANING

Extractors are designed for ferrous metal separation in high volume dry processing applications. These high performance Extractors feature powerful parallel permanent magnets for continuous operation to capture ferrous tramp metal from direct material flow.

Operation

As material enters through the Extractor's inlet, it passes over a diverter which angles the product flow toward the magnets. Ferrous metal that is mixed in with the product flow is then captured and held by the powerful magnetic field.

The Extractor is designed to simplify the cleaning process to encourage frequent and quick removal of collected tramp metal.

Standard models are equipped with an EZ-clean stripper drawer to easily remove collected metal from the housing (metal must only be removed from the housing while the line is shut down). Extractors are also available in air-actuated self-cleaning models for automated or remote cleaning.



EZ-Clean Extractor
Shown Above

FEATURES:

- » T304 Stainless Steel construction
- » Gasketed door for dust control
- » Positive locking clamps for drawer on all EZ-Clean Extractors

SPECIFICATIONS:

- » T304 Stainless Steel housing
- » Food Grade Silicone gasket on door

FLOW RATES:

- » Any product that passes through the matching chute size will pass through an Extractor.

OPTIONS:

- » Ceramic or Rare Earth magnetic circuit
- » EZ-Clean or air actuated Self-Cleaning
- » Custom sizes and transitions
- » Super strength 45MGOe Rare Earth circuit
- » Other Stainless Steel Grades available
- » Food grade and sanitary grade construction
- » Treated contact surfaces for highly abrasive products
- » Collection pan to catch the ferrous metal after it is cleaned from the Extractor
- » Rear access door

TOLL FREE **1.888.582.0821** imi@magnetics.com



Specifications and Dimensions For Extractor Magnets

Notes: When ordering Extractors add "C" for Ceramic, "R" for Rare Earth, where you see the blank () in the part number. Example: EX0808C is a Ceramic EZ-Clean Extractor and EX1008RSC is a Rare Earth Self-Cleaning Extractor.

EZ-Clean Extractor Dimensions:

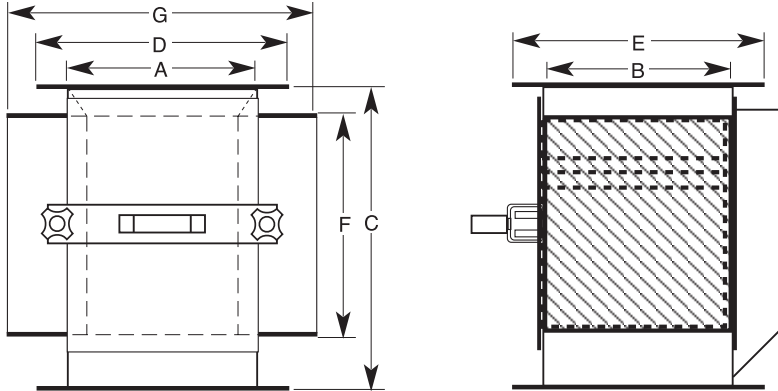

MODEL	A	B	C	D	E	F	G (WIDTH) CERAMIC	G (WIDTH) RARE EARTH	WEIGHT (LBS.)
EX0808_EZ	8	8	14	11	11	8.25	14-1/2	11-5/8	145
EX1008_EZ	10	8	14	13	11	8.25	16-1/2	13-5/8	150
EX1010_EZ	10	10	14	13	13	8.25	16-1/2	13-5/8	185
EX1012_EZ	10	12	14	13	15	8.25	16-1/2	13-5/8	225
EX1016_EZ	10	16	14	13	19	8.25	16-1/2	13-5/8	295
EX1020_EZ	10	20	14	13	23	8.25	16-1/2	13-5/8	370

All dimensions are stated in inches

SELF-CLEANING EXTRACTOR DIMENSIONS:

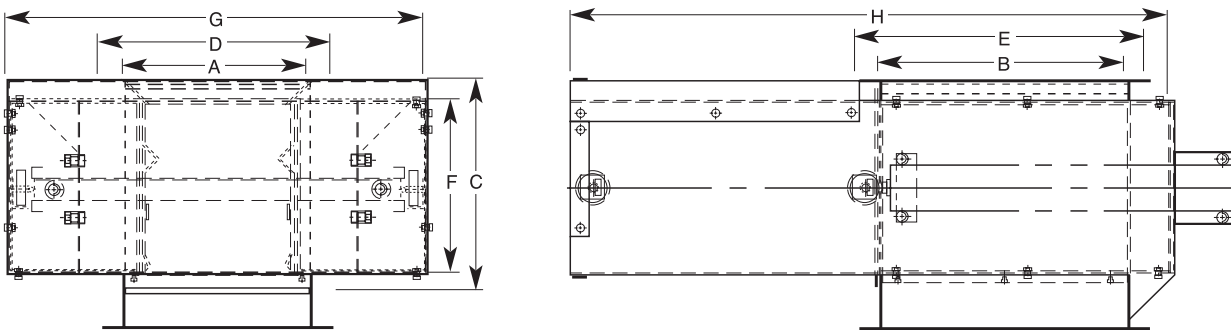

MODEL	A	B	C	D	E	F	G (WIDTH) CERAMIC	G (WIDTH) RARE EARTH	H	WEIGHT (LBS)
EX0808_SC	8	8	14	11	11	8.25	23-1/2	20-5/8	27-7/8	145
EX1008_SC	10	8	14	13	11	8.25	25-1/2	22-5/8	27-7/8	150
EX1010_SC	10	10	14	13	13	8.25	25-1/2	22-5/8	31-7/8	185
EX1012_SC	10	12	14	13	15	8.25	25-1/2	22-5/8	35-7/8	225
EX1016_SC	10	16	14	13	19	8.25	25-1/2	22-5/8	43-7/8	295
EX1020_SC	10	20	14	13	23	8.25	25-1/2	22-5/8	51-7/8	370

All dimensions are stated in inches

